

The Local Reference Electrification Model:
A Comprehensive Decision-Making Tool for the Design of Rural
Microgrids

by

Vivian Li

B.S. Chemical Engineering
University of California, San Diego, 2011

SUBMITTED TO THE INSTITUTE FOR DATA, SYSTEMS, AND SOCIETY
IN PARTIAL FULFILLMENT OF THE REQUIREMENTS FOR THE DEGREE OF

MASTERS OF SCIENCE IN TECHNOLOGY AND POLICY
AT THE
MASSACHUSETTS INSTITUTE OF TECHNOLOGY

JUNE 2016

© 2016 Massachusetts Institute of Technology. All Rights Reserved.

Signature of the Author: _____
Institute for Data, Systems, and Society
May 13, 2016

Certified By: _____
Jose Ignacio Pérez-Arriaga
Visiting Professor, Sloan School of Management
Professor, Electrical Engineering, Comillas University
Thesis Co-Supervisor

Certified By: _____
Claudio Vergara
Postdoctoral Associate, MIT Energy Initiative
Thesis Co-Supervisor

Accepted By: _____
Munther A. Dahleh
William A. Coolidge Professor, Electrical Engineering and Computer Science
Director, Institute for Data, Systems, and Society
Acting Director, Technology and Policy Program

The Local Reference Electrification Model:
A Comprehensive Decision-Making Tool for the Design of Rural Microgrids

by

Vivian Li

Submitted to the Institute for Data, Systems, and Society on May 17, 2016
in Partial Fulfillment of the Requirements for the Degree of Master of Science in Technology and Policy

ABSTRACT:

Current estimates indicate that an alarming 1 billion existing people still lack access to electricity around the world. Technological advancements have pushed off-grid solutions into the limelight as possible alternatives to the traditional method of electrification via extension of the centralized grid. When grid reliability is poor, the community is remote, or when the arrival of the grid is undetermined, off-grid systems may be suitable substitutes for traditional grid extension efforts.

Nonetheless, severe resource constraints, the scale of planning, and the choice between electrification modes create a complicated environment under which planners in the developing world must devise electrification plans and relevant policies. This thesis demonstrates how computational tools can provide value to rural electrification planning. The Reference Electrification Model (REM) assists planners by identifying optimal regions for grid extension projects and off-grid solutions, along with technical design and associated financial metrics. In particular, this thesis focuses on the discussion of the Local Reference Electrification Model (LREM), an adaption of REM to localized electrification design. LREM is a comprehensive, decision-making tool that produces detailed generation and network designs for a singular microgrid system. It contributes to the electrification effort by providing the quantitative basis with which to explore financial, technical, and performance implications of various factors in microgrid design. In doing so, LREM improves the microgrid designs relied upon by REM in its regional planning decisions.

This research emphasizes the ability for computational tools such as REM and LREM to assist in developing viable policies and regulations, as well as feasible designs and plans to accelerate electricity access globally.

Acknowledgements

I could not have asked to be part of a better team. I would like to thank:

- Professor Ignacio Pérez-Arriaga, for his tremendous dedication as an advisor and teacher. I have appreciated, especially, the times in which you have literally ran from the hotel after a 10+ hour international trip, in order to fit me in between 10 back to back meetings. I have drawn so much from your bottomless knowledge and insight on the topics of regulation and power systems. You have my deepest thanks for your tutelage (and also the endless supply of chocolate);
- Dr. Robert Stoner, for introducing me to the field of rural electrification, and for your continued guidance thereafter on the topic of energy development. This work has challenged me to view the world from a larger perspective;
- Claudio, who has the knowledge (and shenanigans) of a thousand engineers, for unfailingly finding time in between your projects and family commitments to help me with all things technical. I have sought more modeling help from you than anyone else - thank you for always being there when I have needed your mentorship;
- Reja, for your calming influence. I admire your ability to never get flustered! You was also the person to come to mind when I have needed to discuss and think through large conceptual ideas;
- Doug and Simone, for your help during those long hours spent trudging through the details of model, and for your persistence in answering my endless questions;
- Professor Fernando de Cuadra and Pedro, for your insight on the behavior and functions of REM;
- Carlos Mateo, for rooting out the source of all my RNM related issues;
- Andres, for consistently saving the day with your bag of gadgets, staying up late with me in India, and for always being so kind;
- Cailinn, Patricia, Stephen, Turner, and Yael, for your comradery and all the adventures!
- The Tata Center staff (Chintan, Nevan, Gail, and Jazy) for taking care of us, even from across the world.

And finally, I would like to thank my family, for their unconditional support.

Contents

Chapter 1: Introduction	8
1.1 Background and Motivation	8
1.2 Research Question	9
1.3 Preview.....	9
Chapter 2: Literature Review	10
2.1 Existing Microgrids	10
2.2 Rural Microgrid Categorization	15
2.2.1 Basic microgrids	15
2.2.2 Intermediate Microgrids	16
2.2.3 Advanced (Predictive) Microgrids:.....	17
2.3 Existing Computational Tools for Microgrid Design.....	18
Chapter 3: The Local Reference Electrification Model (LREM)	20
3.1 The Reference Electrification Model (REM).....	20
3.1.1 Inputs	20
3.1.2 Architecture of REM.....	21
3.1.3 Exemplary Results from REM.....	25
3.2 REM Applied to Localized Design	26
3.2 Architecture and Flow.....	27
3.3 Description of Data Inputs and Functions.....	28
3.3.1 Demand Node Inputs	28
3.3.2 Input of Location Specific Data: Settings, Generation Catalog, and Network Catalog	28
3.3.3 Building of Demand (Load) Profiles	29
3.3.4 Generation Investment Design	30
3.3.5 Generation Investment Cost Calculations	32
3.3.6 Network Design.....	34
Chapter 4: Operational Design of Microgrid Systems	36
4.1 Overview	36
4.2 Power System Architecture	36
4.4 Reliability.....	37
4.5 Battery Model	38
4.6 Operational Strategies	39
4.6.1 Overview	39

4.6.2 Energy Balance	41
4.6.3 The Simplest DC Strategy	42
4.6.4 The Cycle Charge Strategy	44
4.6.5 The Load Following Strategy	46
4.6.6 The Forward Looking Cycle Charge Strategy	48
4.6.7 The Advanced Battery Valuation Strategy	50
4.7 Technical Management Needs	52
Chapter 5: Scenario Analysis with LREM: A Demonstrative Exercise	54
5.1 Overview	54
5.2 Karambi Village	54
5.3 Inputs	58
5.3.1 Labor:	58
5.3.2 Inverter/Rectifier	58
5.3.3 Charge Controller	59
5.3.4 PV Panels	59
5.3.5 Battery	60
5.3.6 The Internal Combustion Engine (ICE)	60
5.3.7 Settings:	61
5.3.8 Network Catalog	61
5.4 Demonstrative Results	62
5.4.1 Network Design	62
5.4.2 Generation Set (kW)	64
5.4.4 Financial Analysis	66
5.4.5 Discussion	67
Chapter 6: Scenario Analysis and Sensitivities	69
6.1 Methods:	69
6.2 Analysis A: Operational Strategies and Fixed Generation Mixes	69
6.2.1 Overview	69
6.2.2 Results	70
6.2.3 Discussion	72
6.3 Analysis B: Operational Strategies and the Optimization Search	76
6.3.1 Overview	76
6.3.2 Results	78

6.3.3 Discussion.....	82
Chapter 7: Conclusions	96
References	97
Appendix	99
Description of Variables.....	99
Flow Charts	100

Chapter 1: Introduction

1.1 Background and Motivation

This thesis contributes to the development of a comprehensive computer-aided support tool for rural electrification planning. Specifically, it focuses on the design of microgrids that are meant to work in isolation from the main connected grid. This research work addresses the lack of computational tools available for electrification planning in the developing world.

In its 2015 Progress Toward Sustainable Energy Report, the UN Sustainable Energy 4 All (SE4All) Council estimated that an existing 1 billion people lack access to electricity. When population growth projections are considered, this number rises to 1.5 billion individuals in need of electricity access by 2030. SE4All further reports that, “the 20 highest access-deficit countries account for 83 percent of the global deficit”, with the majority concentrated in Sub-Saharan Africa and South Asia. 87% of the un-electrified population is estimated to be located in rural regions (IEA, 2015).

The roadmap to electricity access in developing countries is complicated by 1) the prospective benefits of off-grid networks and uncertainty of where they should be developed, and 2) severe resource constraints. Not only must policymakers and planners decide how to design feasible networks, they must also choose the electrification mode best suited for each region. Given this, serious electrification efforts can be facilitated by robust, large-scale models capable of providing the analytics to make viable decisions in a complex environment.

The Reference Electrification Model (REM) is a computational tool that aids in the electrification planning of large areas¹. Using spatial and other descriptive input data, REM identifies regions best served by centralized grid extension and regions where off-grid systems are more appropriate. Each run results in the mix of microgrids, grid extension networks, and single home systems that minimizes overall regional electrification costs. Along with this, preliminary technical designs, and performance and financial metrics are outputted. Unlike existing tools surveyed by the team, REM’s design process begins at the building level granularity, allowing critical spatial consequences to be considered in its analysis. These attributes set REM apart as a valuable asset in the identification of investment options or exploration of policy alternatives. To date, the team’s pilot efforts have demonstrated the tool’s ability to handle regions on the scale of the Vaishali District in Bihar, India, consisting of approximately 600,000 consumer points, or the entire country of Rwanda.

This thesis aims to accomplish two primary model developments: 1) improve the design of off-grid systems (the thrust of this effort has been directed towards the improving and developing a suite of operational strategies), and 2) adopt REM into a tool capable of producing detailed microgrid designs suitable for the rural context. We call this second functionality “Local REM (LREM)”. Motivation for this work stems partly from the needs of REM. The decision between grid extension and off grid solutions relies on the microgrid design module to assess the economic tradeoffs between network options (grid extension, microgrid, SHS). As such, REM’s off-grid system designs must be robust.

¹REM has been developed over the last 3 years by a joint team from MIT and Comillas University in Madrid, supported by the Tata Trusts, Enel, and Iberdrola. Network design in REM is done with the Reference Network Model, developed by IIT Comillas to design optimal distribution networks in Spain. It is a mature tool whose performance has been robustly tested and validated by several Spanish utilities.

The second major motivation for this work was the lack of comprehensive, open source tools specific to rural microgrid design. Microgrid development currently faces strong operational challenges. Globally, projects have been constructed and operated with both public and private funds with varying rates of success. While the proliferation of rural microgrids has been substantial, many business models have ultimately been proven unviable or have not scaled sufficiently (Schnitzer et al., 2014). In lieu of specific tools, we have often observed microgrid design to be based on “rules of thumb”. For example, the battery bank may be sized to meet demand for n number of days, in case of poor weather conditions. Sometimes, a blanket approach is taken, in which a single oversized system is built first, and demand is promoted afterward. For instance, our team knows of one company that constructs “cookie-cutter” systems with capacities that far exceed the basic levels of demand expected in its project villages. After installation, the developer seeks to increase consumer load by promoting commercial activity. Such methods result in generation assets that are not properly sized for the expected load.

The literature suggests that the choice of generation sizing and operational planning can substantially affect the success of a microgrid project. Schnitzer et al. (2014) identified strategic planning as a strong contributor to the success of a project, noting the “importance of considering a diverse set of factors that affect the technical design of the microgrid system”. Moreover, the “Mini-grid Design Manual” published by the Joint UNDP/World Bank Energy Sector Management Assistance Program (ESMAP) (Schnitzer et al., 2014) discusses the importance of proper generation sizing to match demand. Oversizing results in excess expenses (which are highly undesirable in a resource constrained setting), while under-sizing leads to customer frustration. Both errors increase likelihood of failure for a microgrid project. LREM seeks to increase the success rates of off-grid projects precisely by allowing developers to engage in “strategic planning” via the exploration of “trade-offs” by which a satisfactory solution will eventually be identified.

1.2 Research Question

This thesis addresses the gaps in current computational microgrid design tools for rural microgrid development. Firstly, I ask: how can we develop a microgrid planning tool suited for the needs of developers in the rural context? With this tool, I then seek to answer the complimentary question: Can such a tool add value to the field of electrification, and if so, how?

1.3 Preview

In Chapter 2, I survey the literature to identify prominent microgrid projects and developers, as well as existing microgrid design tools. Chapter 3 is devoted to describing LREM and its relationship to REM. I will delve into the specifics of the utilization sequence and explain its major functions. A complete discussion of the operational design of microgrids will be conducted in Chapter 4, where I shall describe the major aspects related to the technical operations of a microgrid and discuss LREM’s heuristic based operational strategies. In Chapter 5, I present a case study to demonstrate the application of LREM to a real project. Exemplary outputs are presented to explain its capabilities and possible uses. Finally, the sensitivity analysis in Chapter 6 provides insight on the behavior of the operational strategies, and on the implications of their usage on the optimal generation design.

Chapter 2: Literature Review

In this chapter, literature discussing existing microgrids and microgrid projects is first reviewed and categorized into three broad bins. This is followed by a summarization of prominent computational microgrid tools, which are reviewed for their advantages and disadvantages.

2.1 Existing Microgrids

Navigant Research estimates the total global microgrid capacity in 2013 to be 3793 MW (Schnitzer et al., 2014). Though only 20% of this capacity is believed to correspond to remote systems, such microgrids are typically of small capacity. Schnitzer et al. (2014) suggest this percentage may be larger if the breakdown were in terms of system number. Indeed, a survey of the current literature finds it peppered with studies relevant to rural electrification. The microgrid design of prominent pilot projects and development companies are summarized in Table 1.

The most notable observation made from the literature was of the substantial diversity amongst microgrid designs. Proprietary devices, hardware, and software appear to be frequently developed, which are perhaps needed to meet specific technical needs of the project, cost considerations, or both. Although this hypothesis cannot be definitively confirmed at this point, our discussions with Indian developers certainly do support it. Further market investigation may be warranted, but is unfortunately outside the scope of this thesis. Nonetheless, the substantial variety in quality and design amongst current microgrids suggests that a standard has yet to emerge from the multitude of rural microgrid studies, pilot projects, and business ventures conducted worldwide.

Table 1. A summary of notable microgrid projects and developers

Study	Generation	Demand and/or Supply Management	Load Size/Load Type	Pilot/Size and Location	Hardware: Custom or Generic?	Notes
Sustainable Control Systems (Smith, N. 2003)	Hydro, synchronous internal combustion engine (ICE)	<ul style="list-style-type: none"> • Current limiters that auto reset with time delay (pole mounted) • Distributed Intelligent Load Controller attached to low priority loads. Curtails current when network falls below frequency thresholds 	Residential and hospital	Pilot/Ugandan village	Developed current limiter and smart load controller – both were commercial, now only current limiter available for purchase (through personal contact with authors)	<ul style="list-style-type: none"> • This is an AC system. • The company develops devices
Mera Gao (Campanella, 2013)	Batteries and PV	<ul style="list-style-type: none"> • Timed service (evening) and a predefined set of appliances • Current is monitored on each distribution line and cut if reaches a certain threshold 	Residential	Company/ India (1200 villages)	Batteries, PV panel, charge controller (appears to be generic, off the shelf)	<ul style="list-style-type: none"> • This is a DC system designed to serve basic lighting and phone charging • A private company
GridShare (Harper, 2012)	Not discussed	<ul style="list-style-type: none"> • When the voltage in the network is low, users are restricted to small loads (brownout mode). A lighting system is used to elicit the state of the network. If an appliance is on at the time of the trigger, a timer starts which allows for a window of time for continued power draw. 	Residential	Pilot/Bhutan	Developed for this pilot project and aimed specifically at many appliances with high power demands. The authors note that Gridshare units have reprogrammable microcontrollers so that thresholds can be set. No communication devices needed	<p>Designed specifically for the management of rice cookers. Helps manage brownout situations – instead of bringing down the network, brownouts are controlled.</p> <ul style="list-style-type: none"> • Pilot was done by a university
Circutor	Solar/diesel hybrid	<ul style="list-style-type: none"> • Energy accrues into pre-paid meter at a pre-defined rate. Consumption rate from meter reflects the state of the system. If the battery has low energy then the discharge rate appears faster to discourage. Once energy in meter is out, then the system gets cut off. • Dispenser can shed load, and includes a relay that can be wired to turn low priority loads on or off 	Households and commercial.	Pilot/ Cape Verde had 80 houses in the village.	Circutor electricity dispensers is a Spanish electrical company and appear to be commercially available. Prototypes and dispensers have been installed in several countries, including Spain, Senegal, and Morocco. Unsure if this is past the prototyping stage (nothing further in the literature could be found).	<ul style="list-style-type: none"> • Specifically, the following buildings are served: “households, a school, a church, a kindergarten, a health center, a satellite TV dish center, three general stores and 22 street lights” • A private company
INENSUS Micro Utility solution (Harper, 2013)	ICE, wind, and PV	<ul style="list-style-type: none"> • Uses a pre-order and trading system to ensure to match load with demand. Consumers have to pre- 	Residential, some businesses (electric rice mill, electric	Pilot/Sine Moussa Abdou Senegal (70 households).	Unclear: Article describes the smart meter, a load	The system is described as a base dispatch logic onto which additional layers of control can be added.

Study	Generation	Demand and/or Supply Management	Load Size/Load Type	Pilot/Size and Location	Hardware: Custom or Generic?	Notes
		<p>order blocks of consumption half a year in advance. Producers purchase modular components.</p> <ul style="list-style-type: none"> • Smart meters can disconnect loads based on frequency of the network 	peanut peeler, electric sewing machine)		<p>limiter that disconnects when current exceeds max thresholds. Specifically, the current limiter can automatically disconnect people based on system frequency</p>	
BOOND ²	Solar and battery	<p>Developed a proprietary smart meter that tracks energy consumption. Payment is done via pre-payment system (also tracked by the meter). System is disconnected when payment runs out.</p>	Single home systems or small microgrids	Pilot phase and some commercial ventures	Develop their own hardware and software because it is often cheaper.	<ul style="list-style-type: none"> • They work with mostly DC, some AC pilots in conjunction with Columbia U. They are unable to provide technical details • Private developer
Gram Power	Solar and battery	<p>Requires an energy selling device. The meter cuts off supply when current draw is too high, and reconnects after load is reduced. Auto shift to different prices of electricity for different types of power generation. Can detect energy theft, priority power allocation</p>	Residential and commercial	Large scale/ thousands of households	<p>Piloted in 2012 in Rajasthan. System consists of solar array, battery bank, inverters, central monitoring system, and propriety pre-paid meters. Most of their equipment is proprietary</p>	<ul style="list-style-type: none"> • Specifics are not clear – info is gleaned from their website and some videos and new articles they have provided • Private developer
TARAUrja ³	Solar and battery, diesel gen as back-up	<p>If any curtailment is done, it is by disconnecting certain feeders connected to a portion of total consumers. Buildings are attached to feeders based on service agreement. The feeders are supplied based on prescribed time</p>	Have serviced commercial and residential.	20 – 30 pilots in UP and Bihar. Strategy is to promote productive usage of power in locations and encourage consumption	<p>Off the shelf items: broadly, solar panels, MPPT charge controllers & batteries (configuration depends on size & type of grid), ATS (Automatic transfer switch) to active our DG set. From email: We have designed our distribution level equipment (load control technology) in-house and through specifically contracted consultants. We source most of our</p>	<ul style="list-style-type: none"> • Private developer

² BOOND. Personal Communications. January, 2016.

³ TARAUrja. Personal Communications. January, 2016.

Study	Generation	Demand and/or Supply Management	Load Size/Load Type	Pilot/Size and Location	Hardware: Custom or Generic?	Notes
					equipment locally from vendors and distributors in India.	
Chhattisgarh Renewable Energy Development Agency (Schnitzer, 2014)	Solar (DC microgrids)	<ul style="list-style-type: none"> • Ineffective DM (overloading) • Provides only 6 hours of lighting a day • Enforcement via personnel 	Provides lighting and phone charging only (2 11 W CFL and plug for phone) – 6 hours a day	More than 500 microgrids in the state of Chhattisgarh, India	Not elucidated.	<ul style="list-style-type: none"> • Designed to meet loads of two 11 W CFLs and cell phone charging • Government agency
DESI Power (Schnitzer, 2014)	Bio-gasifier , ICE as backup	Houses were initially connected to circuit breakers, but they eventually were disabled. As of 2013, DESI Power hoped to begin rollout of wireless monitoring via wireless control system and metering.	Residential with anchor loads, such as irrigation pumps and refrigeration. They attempt to develop commercial loads	Bihar	Not elucidated	<ul style="list-style-type: none"> • Operational problems with the gasifier is prevalent • Private developer
Green Empowerment (Schnitzer, 2014)	Micro-hydro	Circuit breakers on each household. Only portion of village is electrified during low river periods. The system suffers from brownouts and downtime due to over draw. During times of low water, feeders are disconnected in rotational order. System disconnection appears to be done manually, but in response to improper usage (such as surpassing contracted load limits).	Residential, community centers, church, schools, e-centers, but no business consumers.	Rainforest in Malaysia	Not elucidated.	Non-profit company
Electricite d’Haiti (EDH) (Schnitzer, 2014)	Diesel generation	The ICEs are oversized and no restrictions are placed on consumption.	Not elucidated beyond the mention of community electrification.	Haiti; Choose highly dense regions such as those downtown	Not elucidated.	<ul style="list-style-type: none"> • Very poor service • ICEs are oversized and run at low power levels • EDH is the national utility of Haiti
Husk Power Systems (Schnitzer, 2014)	Biomass gasifier	<ul style="list-style-type: none"> • Basic fuse – blown when current draw is too high and must be replaced • Mini circuit breakers that trip when power exceeds limit (manual install, not useful for low loads) • Pre-paid meters that limits energy consumption • Prohibition of incandescent bulbs • Provides only 5-6 hours of service 	Supplies electricity to villages, but specifics are unclear	84+ plants, Bihar, India	Not elucidated.	<ul style="list-style-type: none"> • Sites are chosen by selecting customers who can pay • Biomass gasifiers have high maintenance needs even on the daily basis. • Biomass requires lower capital than PV panels • Suffer from theft and over-usage (for example, ignoring appliance restrictions and bypassing meters) • For-Profit company
Orissa Renewable Energy	PV with small battery bank	<ul style="list-style-type: none"> • No other effective schemes in place 	Minimal residential load of 2 lights and a phone charger	1000 + projects (63+ microgrid, others	Not elucidated.	This is a government funded agency

Study	Generation	Demand and/or Supply Management	Load Size/Load Type	Pilot/Size and Location	Hardware: Custom or Generic?	Notes
Development Agency (Schnitzer, 2014)		<ul style="list-style-type: none"> • 3-4 hours of light and phone charging 		with single home systems)		
West Bengal renewable Energy Development Agency (Schnitzer, 2014)	PV, biomass, PV-biomass hybrid, wind-diesel hybrid	<ul style="list-style-type: none"> • Mini circuit breakers and load limiters • 6-11 pm service 	Provides electricity to villages, but the specifics are unclear	20+ microgrids	Load limiters were customized	Government funded agency

2.2 Rural Microgrid Categorization

The diversity amongst existing microgrid systems warrants a useful method of categorization. Given the potential combinations of features (which are innumerable), the procession from one type of microgrid into the next might be best described as a continuum. I characterize the existing microgrids by system observability, which is a qualitative measure of the sophistication of features that relay data of the current or forecasted state of the system.

Before launching into the discussion of microgrid types, it is useful to define the following terms as used in this thesis:

- **Dispatch:** Dispatch refers to the schedule of generation resources to meet the load, or expected demand.
- **Operational strategy:** The operational strategy refers to the combined interaction of the dispatch logic and demand and supply management strategies, which defines the *overall* operational behavior of the system. Curtailment mechanisms are particularly important to account for in the operational strategy because they affect the load profile or total consumption and reliability estimates.

To provide an illustrative example, an advanced Load Following operational strategy may describe the dispatch logic in which the internal combustion engine (ICE), when needed, always attempts to follow the load (as opposed to outputting at higher power to charge the battery, for example). To ensure operational feasibility however, the microgrid may use a number of devices or mechanisms to aid in capacity management. For instance, when demand exceeds generation capabilities, the system may automatically trigger a disconnection of an entire feeder as a load management strategy. The simulation of the operational strategy must therefore describe the expected dispatch logic *in consideration of the feeder disconnection phenomenon*.

- **System design:** The term “system design” refers to the total technical design of the system (including equipment and software) that enforces and reflects the operational strategy desired. There are multiple ways a system could be configured to implement a particular operational strategy. For example, if the strategy calls for disconnection to occur when power draw exceeds a threshold, a number of different devices (load limiters or customized hardware for instance) can be implemented.

2.2.1 Basic microgrids

The most basic microgrids *lack observability of the system*. This type of system does not have the hardware needed to sense its current state, and its ability to react is limited. Such systems may be the least capital intensive to design and construct, but may have poor service quality. Without observability of the current state of the system, dispatch decisions cannot be made. Energy supply is guided only by natural energy balances. Moreover, these microgrids rely on simple supply management strategies, but do not implement physical means of enforcing control. Prime examples of the basic microgrid are the simplest DC microgrids consisting of battery and storage and serving DC load.

The most basic supply management strategies operate on the expectation (perhaps somehow incentivized) that consumers will comply with predefined rules. Examples include:

- Restrictions on service hours or appliance. Appliance restrictions, such as the use of efficient lighting and appliances, can lower peak load and overall electricity use. Limiting appliances with excessive power draw can also prevent over consumption (Harper, 2013).
- Load scheduling can ensure that peak power draw does not overwhelm the system by providing power to consumer types at predefined times. Appliances or operations that require high levels of power can be restricted to times of low demand. In one Peruvian village, welding was only allowed in the afternoon (Harper, 2013). Another microgrid in Nepal directed power use for grain mill use during the day, and water pumping was allowed at night (Harper, 2013).

Mera Gao, an Indian microgrid developer, provides basic DC service to meet the needs of two lights and a phone charger per household. It deliberately restricts customers' power usage by providing the appliances for their systems and limiting the number of sockets provided (Harper, 2013). Though seemingly a simple concept, the enforcement of such strategies is difficult. Past cases have shown that restrictions may not always be followed by residents. One microgrid in Laos experienced overloading in their system when consumers attempted to use restricted appliances and caused the ICE to burnout (Harper, 2013). Similarly, the Chhattisgarh Renewable Energy Development Agency (CREDA) in India has encountered consumers who attempt to connect restricted devices (Schnitzer, 2014). Without equipment to enforce policies, many of these simple demand and supply management strategies fail. CREDA suggests that community based enforcement can be effective, and studies have observed this mechanism to be successful in reducing brownouts and system overload (Schnitzer, 2014) (Harper, 2013). Researchers of a pilot study in Indonesia attributed the success of the community's efforts to the particular village structure and culture (Harper, 2013).

Due to the lack of system observability, billing options for the most basic microgrids are limited. Mera Gao, for instance, charges a fixed monthly rate regardless of the actual energy consumed (which is untracked) (Campenella, 2013).

2.2.2 Intermediate Microgrids

Microgrids of the intermediate type have *the ability to detect or measure the state of the system and react appropriately*. A distinguishing point of intermediate microgrids is that they cannot consider future data; decisions are made based on the *current state* of the system. Microgrids of this type may have:

- Battery monitoring devices for estimating state of charge
- Inverters (advanced or basic) for voltage control
- Meters to track volumetric energy consumption.

The ability to sense the current state allows ICEs to be dispatched based on heuristic rules or an optimized schedule. The same holds true for supply and demand management strategies. System observability grants these systems the ability to enforce supply or demand management strategies. For example:

- Pre-paid meters can be used to provide volumetric control.
- Disconnection strategies can provide volumetric or capacity control. Some meters can disconnect a demand node when its energy consumption exceeds the threshold. Power limits can be managed with current limiters that trip if current draw exceeds a specified value. Manual means of disconnection such as the switching of breakers to connect or disconnect feeders, for instance, when battery state of charge is low, is another option.

More advanced microgrids of this category often require proprietary devices to implement its specific operational strategy. On the island of Santo Antao in Cape Verde, the “electricity dispenser”, a smart meter, is issued in every house. Power is pre-paid for and dispensed at a contracted rate. Household consumption in relation to available power is relayed to the consumer via the metering device. The company calls this allocation system the “Energy Daily Allowance”, described by Briganti et al. as “a tank ... trickle filled constantly at the rated rate, and emptied when energy is consumed”. The system conveys signals to either encourage energy use or curtailment, depending on the status of the system. High consumption in the network is also relayed by the meter in real time to each household in the form of raised prices. This encourages energy management and allows customers to increase their economic efficiency (Briganti, 2012). Briganti et al. report that consumers have expressed a high level of satisfaction and have been able to effectively adapt their consumption to the economic signals. Furthermore, the pre-payment system in conjunction with controlled power allocation also allows the operator to plan more effectively.

A pilot study in Bhutan implemented a simpler signal system that also required proprietary hardware. Prior to intervention, the demand from rice cookers around meal times would cause daily brownouts in the village. GridShare, an advanced energy meter, was developed with the intent to stagger power draw and decrease the peak load. Each household was equipped with an indicator light. During normal operation, the light would remain green, but once voltage dropped below threshold levels, power would be cut off for devices with power ratings above a defined level, and the indicator would turn red (Quetchenbach, 2012). This system was found to be successful in improving quality of service (Harper, 2013).

The technical sophistication of intermediate microgrids allows for more complex tariffs to be implemented. Well-designed tariff structures can offer price incentives for users to restrict load during times of heavy use (Harper, 2013). Tariff structures can be broadly divided into two types:

1. Consumption based: Such tariffs are based on actual measured energy consumption and are more appropriate for energy limited microgrids since they tend to encourage energy conservation
2. Capacity based: This type of tariff is based on the maximum allowed power use. Charging based on capacity may ease the billing process, but may not be appropriate for energy-limited grids.

2.2.3 Advanced (Predictive) Microgrids:

The most advanced microgrids *can anticipate future conditions*. Forecast allows the dispatch decision to consider future availability of resources, thus informing instantaneous choices. For example, if a system is aware of excess in solar insolation in the following day, it may choose not to run the ICE or to run it at a reduced rate to charge the battery in a current hour. If forecast quality is accurate, the generation resources can be better managed and operational costs will decrease. Forecasting capabilities also allow microgrids to react in anticipation of future resource availability by managing supply appropriately, or by eliciting desired demand responses. A hypothetical example is a system which reacts to predictions of low solar insolation by increasing prices to curb demand in order to meet essential load during those days.

The remote village of Huatacando in the Atacama Desert, Chile was outfitted with an advanced microgrid system. The microgrid was designed to provide 24 hour service supplied by a photovoltaic plant, a wind generator, an ICE, and a lead acid battery bank. The system functions via a customized Energy Management System (EMS). The EMS is responsible for providing generation set points to the ICE, the inverter, and the PV plant, for relaying signals to elicit demand response from consumers, and for

switching the water pump on and off. The EMS also computes the dispatch by solving a mixed integer linear programming based unit commitment with rolling horizon strategy. The dispatch is initially solved with 2 day-ahead forecast of the weather, water consumption, and demand, and then updated every 15 minutes based on updated forecast of future conditions (Palma-Behnke et al, 2013). Although the Huatacando microgrid has been successful (and is still functional today), neither funding nor long-term financial affordability was ever a concern due to a generous sponsor. These conditions have incubated an excellent pilot project, but the same system may be impractical in the resource-constrained context of the developing world.

2.3 Existing Computational Tools for Microgrid Design

A survey of existing microgrid design software revealed a lack of comprehensive and rigorous computational tools created specifically for use in the rural context. Most are created for microgrid design in the developed world and are overly complex for the needs of most rural microgrid developers. A summary of prominent microgrid design tools is provided below.

HOMER⁴: HOMER is amongst the most well-known tools available for generation sizing of microgrids. Historically, the user would define a range of generation sizes, which create the search space for generation sizing. HOMER would then simulate operations across those configurations to find the lowest cost, feasible set that meets the inputted constraints. Although the original sizing search is still available, HOMER has recently added a new feature to allow the computation of the optimal set of generation assets. Once the optimal result has been identified, HOMER computes operational statistics summarizing diesel, renewable generation, and battery throughput and outputs summary financials. Although originally developed by the National Renewable Energy Lab (NREL), HOMER is no longer maintained by NREL and is under private ownership. Updates and improvements are still being made to the model, but later versions are no longer freely available.

DER-CAM⁵: The Distributed Energy Resources Customer Adoption Model (DER-CAM) is a decision support tool developed by Lawrence Berkeley National Laboratory and the U.S. Department of Energy. It optimizes generation and operational design of microgrid projects and provides accompanying analytics. The model is a Mixed Integer Linear Program (MILP), run on default with two objective functions, cost and CO₂ minimization. Other objectives can be specified. DER-CAM is a sophisticated tool that can account for a multitude of generation sources (including PV, solar thermal, numerous storage types, EV, ICE) and site specific inputs (electricity and gas tariff data, site weather data). The model, however, was made for the design of highly complex and sophisticated systems. Some assumptions may not be suitable for the rural microgrid. For example, by simulating operations via optimization methods, DER-CAM assumes that the microgrid system is capable of optimization. This is not a practical assumption for most rural microgrids as hardware may be too expensive.

Hybrid2: Hybrid2 is a detailed model specializing in operational simulation for the prediction of hybrid system performance. It incorporates probabilistic analysis to account for variations in resources and demand. Hybrid2 requires detailed data resources inputs, and allows the user to choose from a selection of dispatch and customize the power system configuration. The model was created with a range of potential users in mind, including the U.S. Department of Energy (DOE), the U.S. wind industry, technical

⁴ References the HOMER documentation from the company website and software (please see References)

⁵ References the DER-CAM documentation from the company website and software (please see References)

consultants, international development institutions/banks, and rural electrification. The major downfall to this tool is that it may be outdated. Hybrid2 was developed in the 1990's, but while the software is still available for download, it is no longer supported (Baring-Gould et al., 1996) (Green et al., Publication Date Unknown).

Network Planner: The Network Planner, designed by the Modi Group at Columbia University, is the tool most similar to REM for regional planning. However, its spatial data resolution, which is defined at the community level, is less granular than that of REM. Each community is comprised of a mixture of residential and non-residential consumer types. The Network Planner calculates the cost of electrification via single home systems, microgrid, or grid extension for each community. The three options are then analyzed to determine the least cost modes of electrification for the entire region. Without building level granularity, the Network Planner loses the informational advantages lent by greater spatial resolution. For example, demand nodes that are widely dispersed may require a more conductor lines in the network, and may not be suitable for microgrid networks. Aggregating the demand nodes into a single village level point eliminates such geospatial details. Furthermore, the Network Planner is not meant to be a microgrid design tool. It provides only summary cost and operational analytics for each community node (Kemausuor et al., 2013), but does not provide detailed technical designs.

Although each tool exhibits strengths, no single one was found to be capable of conducting complete microgrid planning, starting from inputs of individual demand nodes and ending with detailed generation and network design. We seek to fill this critical need by developing a comprehensive planning tool that combines the strengths of the existing tools in a useful way for rural microgrid developers.

Chapter 3: The Local Reference Electrification Model (LREM)

The Reference Electrification Model (REM) is a static, techno-economic model created to support regional electrification planning. Its objective is to determine the least cost mode of electrification for each demand node in a study region. In doing so, it ultimately identifies areas suitable for grid connection and areas ideally electrified by off-grid systems within a large region. When using the term “least-cost”, it is important to highlight that REM approaches the problem from an altruistic policymaker’s point of view. Its objective function seeks to minimize the overall annuity, including *social costs*. Because it is a static tool, REM outputs the investment design for the final design year without optimizing the trajectory to the final results. The inputs and design stages in REM are described below⁶.

3.1 The Reference Electrification Model (REM)

As discussed in Ellman (2015), REM chooses to use cost minimization as the objective function because rural electrification generally operates in economically constrained contexts. This assumption also holds true for singular microgrid design. Microgrid developers in the developing world tend to work in very constrained settings. Their consumers have low levels of affordability, willingness to pay, or both. Many projects struggle to meet running costs and recover investment, let alone profits.

3.1.1 Inputs

REM requires inputs on the regional and demand node level:

- a. **The generation catalog:** This holds the information regarding the equipment used in the generation design including batteries, charge controllers, PV panels, diesel generators, and inverters. The technical parameters and costs of each piece of equipment are required. Further details are found in Chapter 5.
- b. **The network catalog:** This holds the equipment used in the network design, including conductors, poles, and transformers. Each piece of equipment is listed along with its technical parameters, failure rates, labor hours, and investment costs. Further details can be found in Chapter 5.
- c. **Demand nodes:** The geographic coordinates of un-electrified consumers (also referred to as demand nodes) must be inputted. This may be done automatically via REM’s image processing step, which detects buildings from satellite imagery. If coordinates are available, the image processing step can be skipped.
- d. **The existing grid:** The geographic locations of the existing grid infrastructure and transformers must be specified. The expected reliability of the existing grid must also be inputted. It is represented by an hourly percentage describing the probability that grid power is available during each hour of the day (Figure 1 presents one example). The reliability of the grid is used in the clustering decision (discussed later in the chapter).

⁶ A complete discussion of REM was conducted in the Master’s thesis of Douglas Ellman (Ellman, 2015), and complimented by the thesis of Yael Borofsky (Borofsky, 2015). The Master’s thesis of Pedro Ciller Cutillas (forthcoming, 2016, IIT Comillas, Madrid) provides an update on developments made to REM. I refer to all three in this summary.

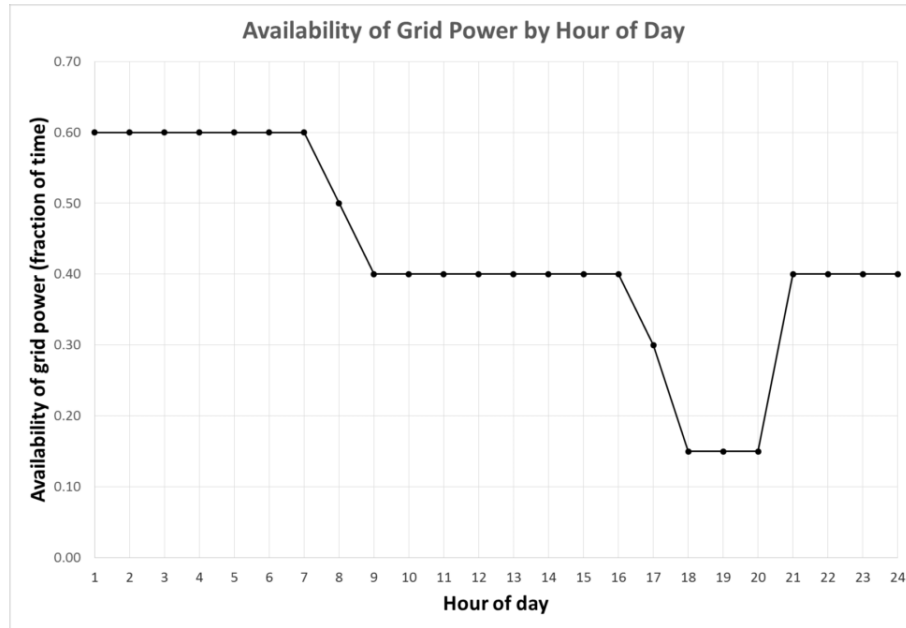

Figure 1. Probability of grid power in each hour of the day (an example), reproduced from (Ellman, 2015)

- e. **Regional boundaries:** This will be used to divide the study region into smaller analysis regions. This is done for computational efficiency; REM solves the sub-regions in parallel to save time. A consequence is that networks in each region are independent of each other. In other words, networks cannot bridge regional boundaries. Regional boundaries can be administrative or based on other context-relevant factors, but the basis should be decided with these limitations in mind.
- f. **Resource availability:** The hourly availability of solar insolation must be specified.
- g. **Temperature:** The expected hourly temperature is needed in the demand building function. It is used to determine when devices are most likely to be used.
- h. **Cost of Non-Served Energy (CNSE):** The CNSE captures the cost arising from a loss of utility incurred by the consumer when his/her power demand is unmet. This value can be subjective, since a value judgment must be made to quantify the lost utility, which may include real and social costs.
- i. **Discount rate:** The discount rate is used to determine the annuity of investment costs.
- j. **Consumer Type:** Each demand node should be labeled with the associated consumer type (e.g. school, residential, commercial business).
- k. **Hourly demand:** Demand is inputted on the appliance level. The appliance set expected to be owned by each type of consumer must be specified along with expected patterns of use. REM will build the profiles based on these inputs. Details will be provided in Section 3.2.

3.1.2 Architecture of REM

This section summarizes the computational steps taken by REM in each run. As will be seen, the identification of the optimal electrification plan is a complex tradeoff between the consequences of spatial orientation, acceptability of service reliability, capital investment, and operations and maintenance:

- 1) **Creation of the Generation “Look-Up” Table:** This is a preparatory step to assist in the subsequent network design (“clustering”) decision process. To increase computational efficiency, the microgrid simulation and design module of LREM is called upon to pre-solve a number of generation designs that correspond to certain combinations of customer types and their demand profiles. Each generation design represents a quasi-optimal solution that is calculated by a heuristic algorithm (Hook and Jeeves, to be discussed later in the chapter). REM considers photovoltaics (PV), battery, and diesel generator technologies as generation sources.

Preparing the “Look-Up” table avoids the need to call on the generation design function during the clustering decision process. Each axis of the table corresponds a consumer type and represents the number of consumers (microgrid size) of that particular consumer type⁷. For example, three consumer types with 5 microgrid sizes each would result in a total of 5^3 demand combinations to solve for. The corresponding generation designs and costs would then be held in the Look-Up table. Critical factors affecting the sensitivities of generation design are, for instance, the relative costs of battery to diesel, as well as the acceptable level of reliability⁸.

Finally, the Look-Up table is “smoothed” to ensure that per customer costs strictly decrease as the microgrid size increases. Designs that deviate from a strictly decreasing pattern are adjusted. A two-part piecewise function is then fitted to the results to ensure that that the per customer generation cost trend is properly captured across all microgrid sizes (Figure 2). The original graph is shown in black, while the final smoothed curve is shown in green and blue.

⁷ Recall that consumer types are defined by their demand profiles. This will be described in detail in a later section in Chapter 3.

⁸ Sensitivities of the generation design will be discussed in more detail in Chapter 6.

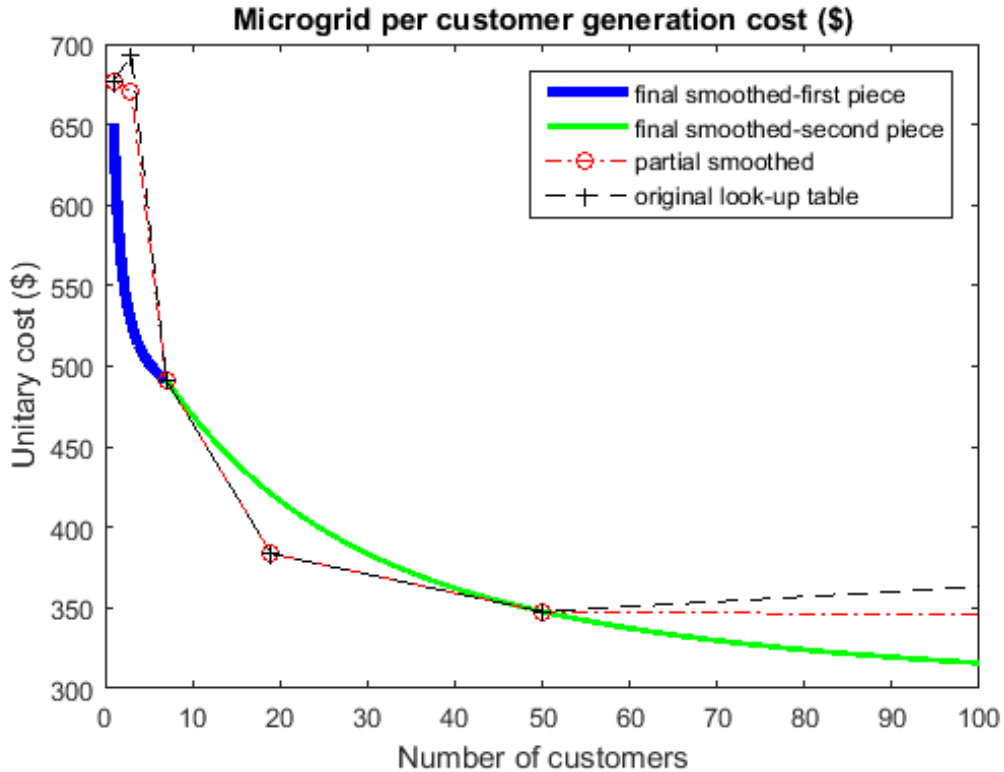

Figure 2. “Smoothed” generation costs per customer (\$/customer) (an example)

- 2) **Off-Grid Clustering:** All consumers will first be assigned to candidate off-grid clusters⁹. To narrow down the potential clustering configurations, a series of candidate “lines” is proposed by creating a Minimum Spanning Tree connecting all consumers. A heuristics based looping procedure is then applied to the candidate lines in order to identify a set of off-grid clusters. Clusters are connected if the generation cost of the aggregate cluster, plus the cost of a line that has enough capacity to satisfy the demand of the least-demand cluster¹⁰, is less than the sum of the generation costs and O&M costs of electrifying them separately. In the clustering decision process, the microgrid designs and costs are estimated from the “Look-Up” table prepared in Step 1. Interpolation techniques are used to estimate generation designs and costs not saved in the table. In general, strong economies of scale exist which tend to favor networks aggregation.
- a. These economies of scale exist in the price of generation assets and operations and maintenance costs. For instance, a smaller battery, tends to cost more in dollars per kWh than a larger one. As another example, several microgrids may be attended by the same worker, and may thusly share those costs, whereas one microgrid would have cover them by itself.
 - b. Economies of scale are highly dependent on the spatial configuration of the networks. One worker may attend to the needs of more microgrids if they are closer in proximity,

⁹ Clusters may consist of one or more consumers. In other words, single home systems are also considered “clusters” in this context.

¹⁰ in this step and the on-grid clustering step, the distribution network design and costs are estimated

but that same number of microgrids will need more workers if they are extremely far apart.

A final note is that a “continuous” generation catalog is used in the estimation of cables and transformers, in which the exact capacity of a line or transformer needed in the clustering process is assumed to be available. This also allows for the superposition of lines, which is needed to estimate reinforcement needs.

- 3) **On-Grid Clustering:** REM then designs the candidate on-grid clusters, given the set of off grid clusters. In step 2, the clustering process started with individual demand nodes and identified the best off-grid clusters to place them in. In step 3, a similar process is undertaken to determine which off-grid clusters should be grouped into on-grid clusters. These on-grid clusters describe only “a group of consumers [who] should be considered together when producing a candidate grid-extension design” (Ellman, 2015). The *final* electrification modes are proposed in the next step.

The on-grid clustering decision process applies a similar looping procedure as is done in the off-grid decision process. Each line in the remaining set of “un-activated” candidate lines identified by the MST represents candidate connections between off-grid clusters. For each candidate connection:

- a. Various configurations of the candidate on-grid cluster are tested, in which either the candidate as a whole, or one of the two off-grid clusters is assumed to be connected to the grid. In each configuration of Figure 3, Clusters 1 and 2 are assumed to comprise of the candidate on-grid cluster. The squares within each cluster represent the MV/LV transformer, and the lines connecting from the transformer are conductors to the grid. Clusters not connected to the grid is assumed to be off grid systems. The cost of connecting to the grid includes those of the transformer, the connecting conductors, and purchased grid power. The overall cost of supplying electricity to the candidate on grid cluster is estimated for each configuration.
- b. The configuration with the least cost is identified.
- c. If the least cost configuration is one which the candidate on-grid cluster as a whole is connected to the grid (Configurations 1, 1', 2, 2'), then the line should be activated

The final on-grid cluster candidates can be comprised of more one or more off-grid clusters.

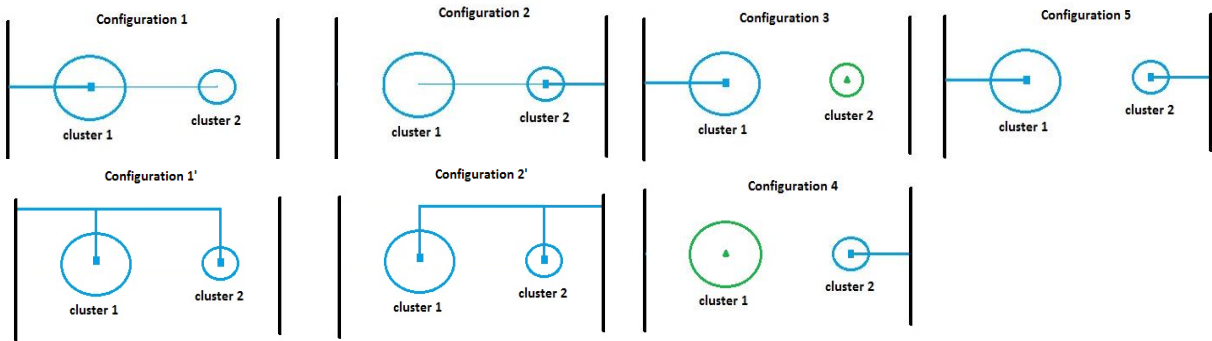

Figure 3. Configurations examined in the on-grid clustering decision process

- 4) **“On-Grid” or “Off-Grid” decision:** At this stage, all demand nodes have been assigned to an on-grid cluster. REM makes a final cost comparison to determine the final electrification mode for

each consumer. While network costs were approximated in the off- grid and on-grid clustering stages, this final step uses detailed network design to provide more accurate network costs.

- a. For each candidate on-grid cluster, the total cost of grid extension is calculated. The total cost of the off-grid and single home systems (which make up the candidate cluster), is separately calculated
- b. If the cost of grid extension is lower than the off-grid costs, then the candidate on-grid cluster should be electrified via grid extension.

Reliability of the existing grid has strong influence on the on-grid clustering decision. When it is poor, the cost of grid connection may be more expensive. Other relevant sensitivities are diesel and battery costs. Both affect the costs of off-grid cluster and influence the choice between electrification modes.

- 5) **Results:** REM outputs the final, least-cost set of single home systems, microgrids, and grid extension designs that electrifies the analysis region. Each building is ultimately be assigned to a system. Also outputted are performance indicators, financial summaries, and relevant statistics describing the electrification design.

3.1.3 Exemplary Results from REM

REM provides a conduit with which trade-offs and sensitivities to various factors can be tested to determine acceptable policies and network plans. This subsection presents an example of the outputs obtained with the latest version of REM for the region of Cajamarca, Peru¹¹. The study region presented in Figure 4 is of the district of Michiquillay, located within the Andes Mountains. All 6,700 households identified are assumed to non-electrified. For this run:

- Diesel prices are assumed to be 2 \$/liter, as a result of the difficult terrain
- The existing grid is assumed to be 100% reliable
- Energy costs purchased from the existing grid are assumed to be 0.45 \$/kWh
- Consumers are assumed to own two lights and a phone charger. There is a 50% probability that the consumers own an additional light. Fans and televisions have 20% and 30% probability of being owned, respectively. The two lights are assumed to be the only critical load in this scenario.
- The cost of curtailing critical demand is very high, at 10 \$/kWh. The cost of curtailing non-critical demand is set to 1.5 \$/kWh.

The results shown in Figure 4 show a diversified mix of all three electrification modes. In general, economies of scale in investment and O&M costs tend to favor networks as opposed to single home systems. Single home systems may nonetheless be justified, for instance, if the houses require low demand, are located significantly far apart from each other, or both. In Figure 4, single home systems are prevalent due to the low population density in this mountainous region. Where consumers are more densely located, microgrid or grid extension networks are recommended. The summary results show that 4,307 costumers, making up the majority of the population, were placed into grid extension clusters. 816 were assigned single home systems, and 1,565 consumers were electrified via microgrid systems. 95% of the total demand was serviced by microgrids. Total annual costs per customer are:

¹¹ Courtesy of Andres Gonzalez, PhD candidate, IIT Comillas, Madrid and Pedro Ciller Cutillas, PhD candidate, IIT Comillas

- 176.75 \$/customer in single home systems
- 159.92 \$/customer in microgrids
- 72.56 \$/customer in grid extension networks

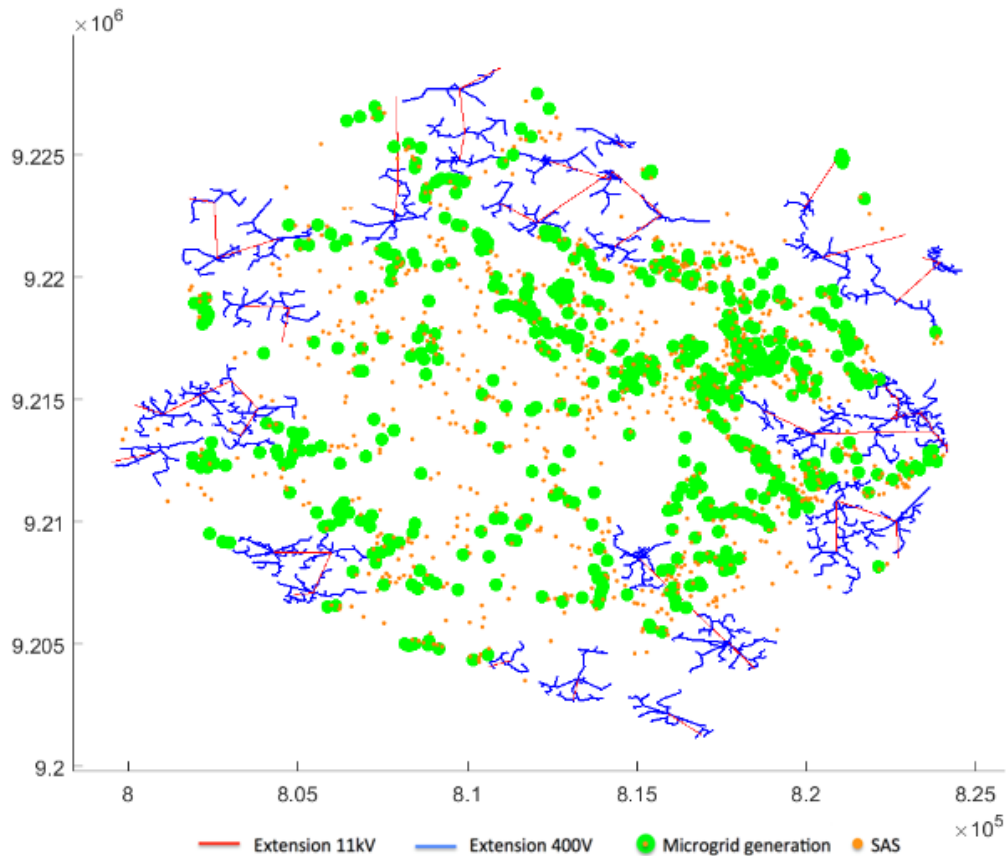

Figure 4. The electrification design of Michiquillay district produced with the latest version of REM

It should be emphasized that the results from REM are influenced by the inputted variables. The sensitivity of the model to spatial factors has already been discussed. Other important factors, for instance, are diesel price and reliability of the existing grid. Grid extension and microgrids are more favorable (relative to single home systems) when demand increases, due partly to economies of scale in costs. However, increased demand may not justify grid extension networks if the grid itself has poor reliability. If this were the case, it may be preferable to implement off-grid systems capable of supply higher quality of service. Even still, off-grid solutions may not be optimal if diesel prices are very high. This discussion of “hypotheticals” is meant to describe the sensitivity of electrification costs and optimal design to an intricate array of factors. REM is designed to provide policy makers with a computational tool to navigate through complex planning questions.

3.2 REM Applied to Localized Design

As discussed in Chapter 1, LREM is an adaptation of REM for local electrification planning. LREM was developed for two main purposes. Firstly, developments made to the operational design aspect of LREM

will improve REM's generation designs. Secondly, LREM seeks to aid developers in making viable decisions regarding microgrid design by providing the analytics needed to conduct technical and financial explorations.

Compared to existing tools, LREM uniquely combines the following features:

- 1) It was designed especially for use in resource constrained environments. As such, it aims to be modular and simple to use. LREM offers a single package capable of computing both generation investment, operational performance, and detailed design of the network starting from the building level. Its network design capabilities have not been identified elsewhere in existing tools.
- 2) LREM focuses on modeling practical operational and technical designs suitable for the rural environment
- 3) Un-needed complexity that may be useful for the developed world, but burdensome in the rural setting has been parsed out. A distinguishing advantage of LREM is that the inputs and financial analysis reflect the cost structure specific to rural microgrid projects.
- 4) Once finished, LREM will be a modular open-source tool. It will provide the essential framework into which other developers may insert and share their contributions.
- 5) Ultimately, LREM should be able to recommend ideal operational design based on characteristics of the demand and other inputs.

The inputs of LREM are a subgroup of those described in Section 3.1 for REM:

- Geographic coordinates of demand nodes
- The consumer type of each node
- Demand inputs for each type of consumer
- Hourly PV insolation data
- Hourly temperature data
- Discount rate
- A generation catalog
- A network catalog

Provided with project-specific data, LREM will compute and output:

- 1) The optimal generation mix
- 2) Estimates of operational performance
- 3) The distribution network design
- 4) Financial estimates

This next chapter describes the technical structure and major functionalities of LREM.

3.2 Architecture and Flow

The logic of LREM follows that of REM, but extraneous functions have been removed while others have been modified or adapted. The most significant difference in LREM is that the clustering function and pre-solved generation Look-Up table are not needed on the local scale. Whereas REM necessarily makes simplifying assumptions for regional planning purposes, data accuracy becomes more important at the localized level. At this scale, small deviations can dramatically affect the overall design.

LREM can be used as a modular package on its own, or it can work as an extension of REM. As such, LREM and REM are simply two modes of the same tool. The work flow of LREM is presented in Figure 5 and can be broken into 4 main parts:

- 1) Inputs and settings building
- 2) Generation Investment
- 3) Network Design
- 4) Results Output

Briefly, input data is provided by users in the Excel templates, read into LREM and subsequently used in the generation investment search and network design. Details follow in Section 3.3.

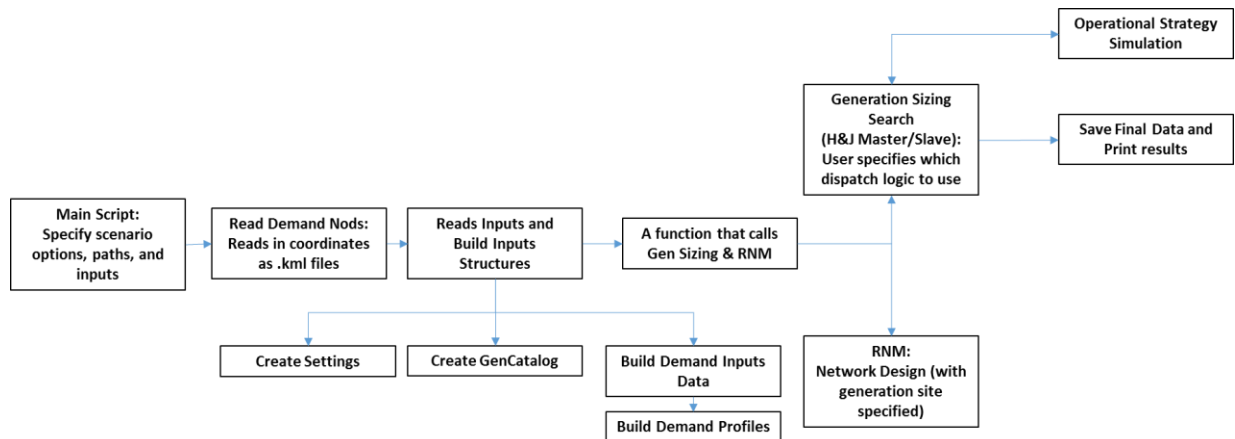

Figure 5. The utilization sequence of LREM

3.3 Description of Data Inputs and Functions

The major functions of LREM shown in Figure 5 will be detailed in the following subsections.

3.3.1 Demand Node Inputs

GPS coordinates of each demand node and consumer type is read into LREM as .kml files. Each category of buildings is saved in a separate .kml file, including one for the coordinates of the generation site. The readBuildings function pulls the GPS data into structures and converts the coordinates from degrees to utm notation. In the final output, each node is associated with its corresponding x and y coordinates and consumer type.

3.3.2 Input of Location Specific Data: Settings, Generation Catalog, and Network Catalog

Settings, generation, and demand data specific to the project/region are inputted into Excel templates. MATLAB reads the data from the spreadsheets into data structures used in LREM. These structures are saved into folders for use in later runs to avoid rebuilding if the input data has not changed. The specific values applied to each case will be discussed in Chapter 5.

1. Settings file: This file contains various settings specific to the microgrid as a whole, miscellaneous items such as the cost of diesel and non-served energy.

2. PVWatts Data: PVWatts is an NREL site that provides historical averages of PV insolation at various points globally on an hourly resolution. It also provides historic hourly averages of temperature. Both are needed in LREM.
3. Generation and Network Catalogs: Equipment available to the developer, technical parameters, and costs are inputted into these spreadsheets. There is a separate file for generation and network components.

3.3.3 Building of Demand (Load) Profiles

Estimation of the demand inputted into spreadsheets. The demand is built from the appliance level based on estimates of probable hours of use for each appliance, probability of ownership, and estimates of appliance numbers. In estimating the load profile, LREM takes into consideration the following factors:

- 1) **Prohibited hours/availability restrictions:** The hours during which the appliance is never expected to be on. The hours outside of prohibited hours are the available hours, which define the hours the appliance can be on.
- 2) **Appliance type and number:** The types of appliances (and number of each owned) and power draw, must be specified for each type of consumer.
- 3) **Variation:** Load is expected to differ from consumer to consumer and from day to day. Variation in the demand build by LREM considers the following factors:
 - a. Appliance Variability: specific to the appliance and meant to describe variation in specific appliance use duration from day to day.
 - b. Day-to-Day Variability: represents variation in overall demand that reflects variation between types of consumers.
 - c. Number of Appliances: if multiples of an appliance are owned, the actual number of appliances that are on will be an integer value between the minimum and maximum number of appliances.
 - d. Probability of Ownership: represents the likelihood a customer of type x owns a particular appliance
- 4) **Resource data:** Demand is built with respect to the resources at hand for the particular location. Lighting is only allowed to be on when the irradiance is lower than a certain threshold, while fans only turn on when the temperature has passed a certain threshold.
- 5) **Average Daily Duration:** The average daily duration in relation to the number of available hours, defines the probability an appliance is on in a particular hour of the day.
- 6) **Daily Duration Criteria:** This is analogous to the average daily duration, but is only applicable to appliances whose use is contingent on a particular variable (i.e. temperature or solar insolation). The fraction of hours the appliance can be on divided by the number of available hours defines the probability the appliance is on in a particular hour of the day.

Specifically, the demand is built via the following steps:

- 1) Each type of consumer is associated with an expected set of appliances. This is inputted in the demand catalog, along with the power draw and average use during the day for each appliance.
- 2) The demand is built one day at a time, and one appliance at a time. For each 24 hour period:
 - a. The expected hours of use for each appliance are specified. This provides a window in the day during which an appliance may be on. The appliances can only be on during this window, but within this block, the exact hours the appliance is on differ in time and duration. Specifically, the probability that the appliance is on during an available hour is calculated based on length of the window and the specified average duration of appliance use scaled by the inputted variation factors:
 1. **Rand** = a random fractional value
 2. **Day_var** = daily variation value (an input)
 3. **App_var** = appliance variation value (an input) $(2 * \mathbf{rand} - 1)$
 4. **Available_hours** = total hours the appliance *can* be on (defined based on time restrictions or *upper threshold limit* (an input))
 5. **Chance_on** = daily duration/available hours
 6. For appliances subject to time restrictions: average duration is an input

$$\mathbf{daily_duration} = (\text{average duration}) * (1 + \mathbf{day_var} + \mathbf{app_var})$$
 7. For appliances subject to threshold limits: average duration is calculated based on number of qualifying hours above the *qualifying threshold value* (an input)

$$\mathbf{daily_duration} = (\text{average duration}) * (1 + \mathbf{day_var} + \mathbf{app_var})$$
 8. For each hour, if $\mathbf{rand} < \mathbf{chance_on}$, appliance is on (note: a rand value is generated for each hour)
 - b. Step (a) is repeated for each appliance.
 - c. The total appliance usage for the day is superimposed (summed) to determine the total hourly load for that day.
 - d. The results are saved and the simulation moves onto the next 24 hours until all hours of the year have been cycled through.
- 3) The above steps are repeated for each consumer type.
- 4) n number of demand profiles is built for each consumer type and saved in a matrix. Each demand node is assigned a random demand profile of its consumer type.

3.3.4 Generation Investment Design

The objective of LREM's generation design is to identify the generation design that results in the lowest annuity. Given the expected demand and the inputs, LREM identifies the optimal generation mix of solar, diesel generation, and storage. Battery and solar panels are assumed to be modular banks, comprised only of multiples of one unit size. LREM chooses the unit solar panel and the unit battery size that has the lowest \$/W price for use.

Formulaically, the generation assets sizing problem is based on complex, highly non-linear relationships between numerous variables (many of which are discrete). Given these characteristics, the solution space is expected to exhibit numerous local minima, complicating the identification of the true global minimum. As such, traditional mathematical programming is an unsuitable solution method. The approach taken by LREM (and REM) is to decompose the generation investment problem into a hierarchical nested optimization structure, to which a structured direct search method is applied. The search space is split into two levels – one comprised of the generator sizes, and the other comprised of the battery and PV bank. The generator size is the independent variable to be solved for in the upper “master” optimization problem. In the lower “slave” optimization problem, the generator size is a parameter, and the independent variables are the PV and battery size. The split is done in this way because batteries and PV tend to function well in parallel and are easily built up incrementally, but the tradeoffs in capacity between generators and PV and batteries is not as straightforward. The search moves in the direction of steepest descent until it has located the lowest annuity within the total search space defined. Figure 6 provides a schematic of the described algorithm:

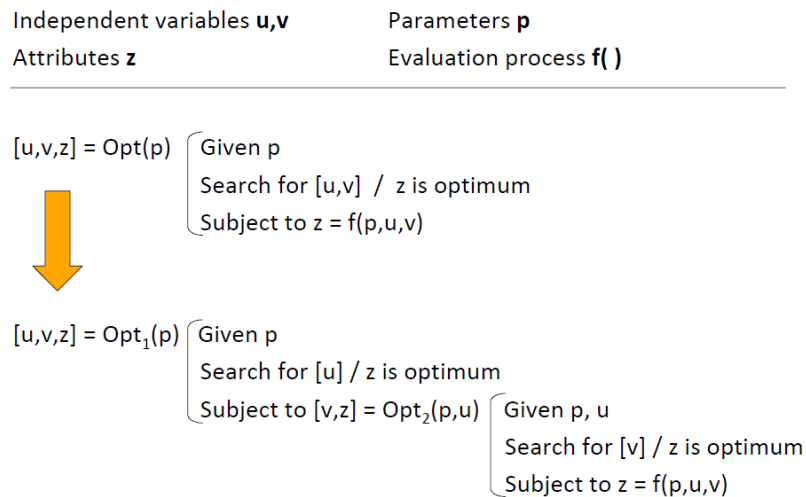

Figure 6. Embedded partial optimization (reproduced from the slides of Dr. Fernando de Cuadra, Professor, IIT Comillas, Madrid)

The exploration proceeds in the following manner:

1. Define the unit size of the battery and solar panel.
2. Define the minimum and maximum number of ICE, PV panel, and battery.
 - a. The maximum battery number should be able to meet 5 days of average demand. The minimum battery number is 0.
 - b. The maximum solar panel number should be able to produce 5 times as much power as needed on an average day. The minimum panel number is 0.
 - c. The largest ICE is the maximum number in the catalog that can output 1.25 times the peak demand. If this exceeds the maximum number in the catalog, then the maximum ICE number should be the largest available number. The minimum ICE size is 0.
3. 100 different equally spaced sizes are defined within the min and max number of each asset. This defines the steps between options during the search.
4. The arrays of PV panels, battery, panels, and ICE sizes are multiplied against the unit size of each asset. This defines the complete search space of the problem.

5. Start the search: Define the starting ICE size in the "Master" layer (the starting ICE size is the smallest one that can cover the peak demand). The "Master" problem sends the ICE size to the "Slave" problem.
6. Given the ICE size from the "Master" layer, a search for the optimal PV and storage banks to accompany the ICE is conducted in the "Slave" partial optimization layer,. The starting battery and PV sizes are 0, and this defines the initial central point. Points around the central point are defined:
 - a. 2 points representing +/- one step on the battery axis
 - b. 2 points representing +/- one step on the PV panel axis
 - c. 2 points representing + one step on the PV panel axis concurrent with +/- one step on the battery axis
 - d. 2 points representing - one step on the PV panel axis concurrent with +/- one step on the battery axis
7. Each point in the "Slave" layer is sent through the dispatch simulation.
8. The point resulting in the best annuity is saved.
9. If the optimal point is the central point:
 - a. Reduce the radius in the search step.
 - b. Keep the central point as the new central point.
 - c. Define new search points around the point per Step 6, but with the reduced search step. If the search step can no longer be reduced (meaning the smallest change in asset sizes have been taken), then the solution has been found.
10. If the point resulting in the best annuity is not the central point:
 - a. This point is set as the new central point keeping the same diesel point.
 - b. Define new search points around the central point per Step 6, using the current search step size.
11. Repeat until the conditions in Step 8c are met.
12. Move to the next smallest ICE size:
 - a. Repeat steps of the search in the "Slave layer", moving down in ICE size, until the best annuity of the next smallest ICE size is found to be greater than the previous ICE size, or until all ICE sizes have been tested.
13. Each generation size has an associated optimal PV and battery mix. The generation mix with the lowest annuity **overall** (across all the best annuities found for each ICE size) is identified as the optimal generation mix.

The steps above describe how the generation design decision calls upon the dispatch simulation. The investment and dispatch are distinct problems, but coupled via an iterative process in which the results of the dispatch inform the ultimate investment decision. Though an alternative would be to solve both in a single step, we choose to decouple the problems because the decisions operate on different time scales. A complete treatment of rural microgrid operational design and strategy is provided in Chapter 4.

3.3.5 Generation Investment Cost Calculations

Given the optimal generation mix and the simulated dispatch, LREM estimates the associated costs and provides financial metrics. Specifically:

- 1) Since LREM deals with single microgrid projects, labor associated with **operations and maintenance** is often accounted for as annual salaries. There is also the option of adding per component O&M costs.
- 2) **One-time fees** are similarly added in as lump sums in the post-processing step. This is because cost structures and accounting differ from amongst developers. Examples could include:

- a. Wiring costs associated with the connection of buildings to the network
 - b. Metering costs
 - c. Development of the generation site, such as a small hut to store generation assets.
- 3) **Installation costs**, comprised of capital and installation costs
- 4) The **annualized investment costs**, which is calculated given the total installation costs and the expected lifetime of each asset (the calculation of lifetimes is described below). The annuity used in the investment decisions is the total annuity, including the social costs arising from curtailing demand.

$$\text{Annualized Investment Costs} = \frac{\text{Installation Costs} * \text{discount rate}}{1 - (1 + \text{discount rate})^{-\text{lifetime in years}}}$$

It is also important to note the following regarding LREM's treatment of costs:

- ICE:
 1. A survey of ICEs by the team indicated that economies of scale exist in ICE cost. Additionally, efficiency tends to increase as ICE capacity increases.
 2. Single speed ICEs are designed to operate at maximum efficiency at the peak power output and are less efficient at power levels below the rated value. Furthermore, operation below the minimum rated power should be avoided, or damage to the engine could result.
 3. Fuel costs from running the ICE are estimated based on a linear piecewise approximation of the efficiency curve specific to the ICE size. ICE efficiency tends to increase as plant size increases. The generation fuel consumption output at each hour is determined based off this approximation.
 4. Start-up fuel consumption is tracked, and costs associated with start-up incidents can be calculated.
 5. Diesel cost should be based on the local price.
 6. The ICE lifetime is calculated by dividing the annual hours of ICE operation by the expected lifetime hours.
 7. ICEs also see economies of scale as capacity increases.
- Batteries:
 1. It is assumed that a battery will have a shelf life of n number of years, even if it is unused (this is known as the float life). The battery lifetime is taken to be the lower of the float life or the value calculated using the lifetime throughput.
- Inverter/Rectifier:
 1. To simplify the search space of generation, the inverter and rectifier are estimated after the generation sizing occurs. The inverter is sized to accommodate the max instance demand within year. The rectifier is sized to accommodate the max instance of DC power into the battery. The converter is then sized to be the max of either the inverter or the converter. The cost is calculated by interpolating between reference sizes in the generation catalog.
 2. The simple DC operational strategy does not need an inverter

3. The lifetime of the inverter/rectifier is simply an input.
- Charge Controller:
 1. Likewise, the charge controller is sized to handle the peak solar power of the year.
 2. The charge controller is not needed when the generation set excludes either PV panels or storage.
 3. The lifetime of the charge controller is simply an input.
 - PV Panels:
 1. Discussion with partners on the ground suggest that PV panels tend to have economies of scale, and that panels decrease in cost per watt (\$/W) as panel size increases.
 2. The lifetime of the PV panels is simply an input.

3.3.6 Network Design

Generation investment and network design are treated as independent problems in LREM. The network design is done with the Reference Network Model (RNM). RNM exists as two different models to accommodate brownfield and greenfield design. The brownfield model attempts to build the new distribution network into the existing infrastructure. The greenfield version, which assumes existing infrastructure is non-existent, is used for rural microgrid design. RNM is also capable of distinguishing between rural and urban settings. For the purposes of REM, RNM assumes a rural setting. The primary difference is that the “rural” option offers more degrees of freedom in the network design, whereas the model is constrained to following the configuration of streets in an urban setting.

The RNM user must specify:

- 1) A network catalog specifying the network component sizes, technical parameters, and costs. The major electrical components used in the network design are low, medium, and high voltage wires, high to medium voltage substations, medium to low voltage substations, and capacitors. The major parameters for each component type is shown below:

	Voltage	Current	Power	Impedance
LV, MV, and HV wires		A		Ω
LV and MV customers, MV/LV transformer substations	kV		kVA	Ω
HV customers, HV/MV substations	kV		MVA ($P_0=kW$)	Ω
Capacitors			kVA	

An example of a detailed table of the low voltage network catalog and transformer catalog is presented in Chapter 5.

- 2) The geographic coordinates of the consumers (who will be connected at the low voltage level), including demand characteristics.
- 3) The geographic coordinates and technical parameters of the generation site (which is treated as an imaginary substation). RNM requires separate files detailing the GPS coordinates of the medium voltage/low voltage substations and high voltage/medium voltage substations. The location of both substations are fixed at the same GPS coordinates and exist simply as “placeholders” for the generation site. RNM will then design the low voltage network and if appropriate, the medium voltage network as well. Practically, the choice of generation siting may not always an easy decision. A large clearing is ideal with minimal sunlight blockages, and may require the land to be “donated” to the project by the owner, or leased to the developer.

4) Regions that cannot be trespassed can be specified.

Given the location of the generation site, RNM designs an optimal distribution low voltage network connecting the demand nodes to the generation site while respecting constraints. Given the low voltage network, RNM will decide if a medium voltage network is needed. Likewise, if a high voltage network is needed (unlikely), the next step is to design the optimal high voltage network. The results provide a technical design including the specific conductor types and lengths in every part of the network. RNM also provides financial outputs of the final design. Further details on RNM outputs are described in Chapter 5.

Chapter 4: Operational Design of Microgrid Systems

4.1 Overview

The full description of the operational design of a microgrid is comprised of a mélange of different attributes. This chapter will discuss these relevant aspects.

4.2 Power System Architecture

The operational design of a microgrid is founded in the system configuration. The tradeoffs between alternating current (AC) and direct current (DC) systems are largely between utility and cost. One significant advantage of AC microgrid is the greater ease with which they may be incorporated into the main grid. If “grid compatible”, a microgrid can be “absorbed” by the centralized grid. The capital invested is thereby not wasted, and generation assets continue contributing to the electricity supply. This could also have carbon emissions implications. On the other hand, given the minimal demand expected from most rural microgrids, the expense of AC systems may be too costly for certain communities with lower willingness or ability to pay [2]. Very simple DC systems may be less capital intensive to install. Mera Gao, arguably the nameplate company for the DC system in India, is able to construct microgrid networks very inexpensively. Its networks are not built to grid standards and provide only very basic electricity for lighting and phone charging. However, DC grids may face appliance limitations. There is currently a greater market for AC devices and most appliances are designed to be used with AC power. Despite this, the number of appliances built for DC power has been progressively increasing. In Uttar Pradesh, for instance, the team witnessed the usage of a small DC TV/DVD combined player drawing a mere 16 W.

The power system can be configured in numerous ways in practice. The exact configuration of the power system directly affects operational efficiency and losses. LREM’s AC based operational strategies assume the ICE is coupled to the AC bus, while the battery bank and solar panels are coupled to the DC bus (Table 7).

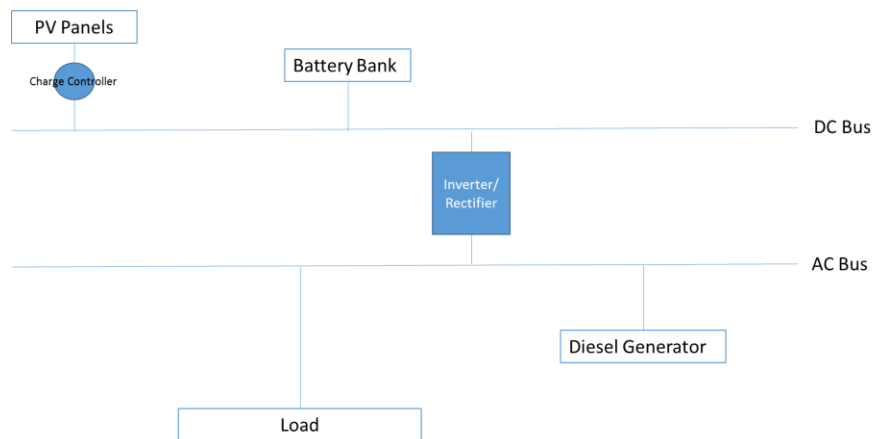

Figure 7. The configuration of AC generation systems in LREM

DC networks have an even simpler configuration. This type of microgrid in LREM uses only PV and battery storage and serves DC load, which eliminates the need for an inverter or AC bus. A diagram of the power system configuration for this type of network is shown in Figure 8.

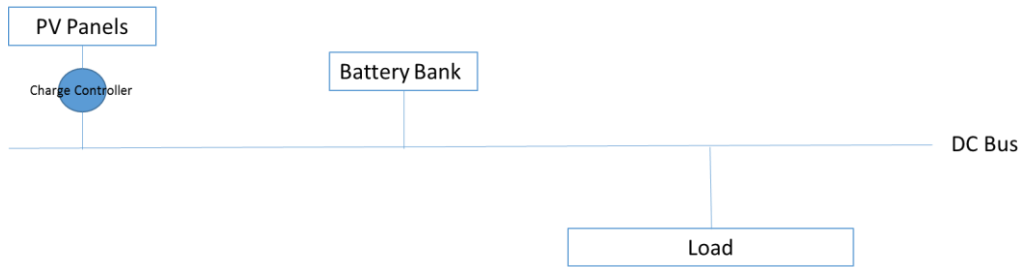

Figure 8. The configuration of DC generation systems in LREM

4.4 Reliability

The service provided by a microgrid should be expected to be held to a certain level of quality. One metric of quality of service is reliability¹². Reliability can be influenced in the model in one of two ways:

1. As described above, The CNSE captures the cost arising from a loss of utility incurred by the consumer when his/her power demand is unmet. A cost must be assigned to curtailed demand for practical reasons. Without it, the least cost system will be one in which no energy is served. The CNSE drives generation design, by affecting the cost of the resulting dispatches. Additionally, more sophisticated operational strategies such as the Advanced Battery Valuation strategy use this value in the dispatch decision to determine whether it is economical to serve load. Simpler operational strategies do not consider this in the dispatch decision.
2. A reliability constraint can also be utilized to force final results to meet *at least* a certain threshold of reliability. This is modeled at the generation search level for LREM's heuristic dispatches, by penalizing solutions that do not meet the reliability target. It is important to note that this is a less straightforward way of implementing a reliability goal, because we have organized the optimization in such a way that the dispatch is decoupled from the generation investment decision. Unlike heuristics based strategies, mathematical programming based strategies can be written to respect a reliability constraint within the dispatch decision.

The basic reliability metric is described by the fraction of demand unserved. However, this measure alone is not intuitive for the consumer because the criticality of power is time dependent. It is far more informative to describe reliability by a metric we have termed the *hour of the day reliability*. For this reason, LREM also computes hourly reliability statistics, which provide an indication of the expected reliability in each hour of the day. If curtailment occurs, the service reliability would likely be poorer in later hours of the night, corresponding to the hours in which the battery begins to run out. Demand may also be expected to be curtailed during hours of very high load peaks. During such times, the load may exceed the maximum power output from the generation assets.

Most systems expect to serve night time demand, and system reliability can only be increased with the inclusion of battery storage or an ICE. In most cases, batteries call for a higher capital investment, but

¹² The metric used to describe reliability here refers to the likelihood the network can met the load when it is demanded.

have lower operational costs. ICEs, on the other hand, are generally less capital intensive but have higher operating costs due to fuel consumption. LREM assists in identifying the most economical generation mix.

4.5 Battery Model

The most commonly encountered battery type in our field visits and research is the lead acid battery due to its affordability, although lithium ion batteries are also infrequently implemented. There are three versions of the lead-acid battery: flooded (also called wet-cell), Gel Cell, and Absorbed Glass Mat (AGM). Flooded lead acids are the least expensive, but they are also unsealed, requiring ventilation and periodic maintenance to replenish water.

Battery University (a web site sponsored by Cadex Electronics) notes that primary advantages of the lead-acid battery (selected here for relevancy to microgrids) are as follows:

- 1) It is one of the least expensive commercial batteries available
- 2) The technology is mature, and as such, is reliable and well-studied
- 3) It exhibits low rates of self-discharge when not in use
- 4) The battery is capable of producing high discharge rates

However, its disadvantages include:

- 1) Lead acid batteries are generally slow to charge. Most types are noted to take 14-16 hours to reach a full charge.
- 2) Lifetimes are moderate and limited to around 200 to 300 cycles due to electrode corrosion and material depletion.
- 3) Charging must be carefully managed in Gel and AGMs to avoid gassing and water depletion which will damage the battery. Thus, they cannot be fully charged and a lower charge voltage limit must be observed
- 4) Battery lifetime deteriorates at higher temperatures. BatteryUniversity.com notes that the ideal operating temperature of a lead-acid battery is around 77 degrees F. Each 15° F increase reduces the expected battery lifetime by approximately half.

The behavior of the battery system in LREM is modeled by the Kinetic Battery Model (KiBaM), developed by Manwell and McGowan (1993), which models the chemical kinetics of a battery using a two tank system. One tank represents the chemical energy immediately available for conversion to electricity. It is replenished by a second tank (representing the bound energy) at a rate proportional to the height of the two tanks. The rate constant k , which describes the flow from one tank to the next, is a constant representing the diffusion rate of chemical ions. Practically, the limits of power charge and discharge in each hour of the simulation are dictated by the KiBaM. The battery's maximum charge power in each hour is imposed by three different limitations, and is taken to be the minimum of the three. The first is from the kinetic battery model itself:

$$P_{battery,max\ charge,1} = \frac{kQ_1e^{-k\Delta t} + Qkc(1 - e^{-k\Delta t})}{1 - e^{-k\Delta t} + c(k\Delta t - 1 + e^{-k\Delta t})}$$

Where:

Q_1 = available energy in the battery at start of time step t (kWh)

Q = total amount of energy in the battery at start of time step t (kWh)

c = battery capacity ratio (unitless)

k = battery rate constant (h^{-1})

Δt = length of time step (h)

The second and third limitations are given by the maximum charge rate and the maximum charge current of the battery.

$$P_{battery,max\ charge,2} = \frac{(Q_{max} - Q)(1 - e^{-\alpha\Delta t})}{\Delta t}$$

Where:

α = the battery maximum charge rate (A/Ah)

Q_{max} = total capacity of battery bank (kWh)

$$P_{battery,max\ charge,3} = \frac{(N_{batt}I_{max}V_{nom})}{1000}$$

Where:

N_{batt} = number of batteries in total bank

I_{max} = maximum charge current (A)

V_{nom} = nominal voltage (V)

The max discharge power in each time interval is provided by the kinetic battery model:

$$P_{battery,discharge} = \frac{-kcQ_{max} + kQ_1e^{-k\Delta t} + Qkc(1 - e^{-k\Delta t})}{1 - e^{-k\Delta t} + c(k\Delta t - 1 + e^{-k\Delta t})}$$

Where:

Q_{max} = total capacity (kWh) of the battery bank

4.6 Operational Strategies

4.6.1 Overview

Power systems dispatch can be based either in mathematical programming (MP) based optimization methods or heuristics. MP methods are guaranteed to identify the optimal solution, subject to a set of constraints. The academic literature is riddled with such dispatch schemes. However, the problem facing MP optimization based dispatch is that they may be impractical to implement. For the rural context, it is

important to distinguish between the idealized dispatch strategy and a practical dispatch strategy. A dispatch strategy must correspond to the actual situation on the ground. By designing a microgrid via MP simulation of dispatch, the user is inherently assuming that such an operational strategy is implementable. Reality may dictate otherwise. For example, the equipment needed to physically carry out dispatched schedules may be too costly, or operational complexity may be too high.

The other “category” of operational dispatches is based in heuristics. Silver et al. (1980) define heuristic methods as procedures “for solving a well-defined mathematical problem by an intuitive approach in which the structure of the problem can be interpreted and exploited intelligently to obtain a reasonable solution”. Such methods “will not be guaranteed to give a mathematically ‘optimal’ solution”. For LREM, the heuristic strategies represent more intuitive and realistic methods with which dispatch can be made. LREM’s five heuristic based operational strategies make decisions based on a set of defined logic and represent various levels of operational sophistication. The most practical options for the rural setting are the operational strategies based on a set of predefined set or rules, or heuristics (the Simplest DC, the Cycle Charge, and the Load following). These strategies are more easily practically enforceable with generic hardware. Others (Forward Looking Cycle Charge and Advanced Battery Valuation) may require customized equipment. This thesis focuses on the discussion of the heuristic based operational strategies.

Microgrid dispatches, whether heuristics or MP based, may suffer from the inability to foresee the future. Forecast capabilities can overcome this limitation by using future considerations to inform current dispatch decisions. However, forecast data describing the expected solar insolation may need to be purchased from companies, though free sources might also be available.

Another aspect of operational strategy is the choice of supply and demand management strategies. The operational strategy and estimate of demand must reflect the supply and demand management capabilities desired. The overall operational strategy of a microgrid is achieved via coordination between dispatch strategy, and supply and demand side management. The two are closely intertwined (since both related to resource management), and together, they define the technical complexity of the microgrid. For instance, the Advanced Battery Valuation strategy reflects the ability to incrementally curtail load as a form of supply management.

Traditional centralized grids have generally conducted supply management, in which electricity supplies are dispatched in accordance to various strategies to meet load. Such systems have access to sufficient generation capacity and resources to reliably meet unrestrained demand. A microgrid, on the other hand, exists in a resource constrained setting. In this environment, supply management alone is no longer suitable. Demand side management is used to influence electricity consumption so as to manipulate the demand load curve to be operationally favorable. In a rural setting, these techniques can supplement supply management to more effectively balance demand and supply.

Demand management techniques and implementation vary in technical and social complexity, and affects both the technical and operation design of a microgrid. Volumetric control manages the total energy consumption, while capacity control manages instantaneous power draw. Both are important for operational sustainability. Excessive power draw degrades service quality, while excessive energy consumption may derail cost recovery depending on the tariff structure.

For microgrids in the rural context, the most prevalent method of demand/supply management identified in the literature was via disconnection methods. This is generally done with available equipment such as

a meter or advanced current limiter, or hardware that is proprietary to the company. More sophisticated curtailment methods were not identified. In the idealized case, for instance, it would be optimal to curtail load incrementally as opposed to a hard “on/off” decision. Additional benefit could be garnered from being able to distinguish between critical and non-critical load. The problem with both is that specialized equipment may be needed for actually implement the strategies.

With regards to modeling operational strategies, curtailment mechanisms are a critical component. The relevant considerations of curtailment in LREM are described below:

- **No curtailment:** The most basic microgrids may not have a physical method of enforcing curtailment. When demand exceeds supply, the voltage will simply drop and service reliability will suffer. The main issue with such a system is the lack of ability to manage the decrease in reliability. Without it, the service quality during such a time cannot be precisely conveyed to the consumer. LREM assumes this is the case for several of the operational strategies: Simplest DC, Load Following, Cycle Charge, and Forward Looking Cycle Charge.
- **Timed Connection:** We assume a practical mechanism of curtailment control via the use of a basic feeder system. Upstream of our generation design, we assume buildings are split amongst multiple feeders that lead to a breaker box controlling feeder connection. Given this, the buildings can be split amongst feeders by level of service. Feeders would only be connected during contracted times, allowing the time restrictive methods of supply management to be physically implemented. For example, low demand consumers may pay to have service only during the most essential nighttime hours. This is implicitly modeled in LREM via the demand profiles. The expected load is built assuming that service is provided only to consumer types during contracted periods of the day.
- **Free Curtailment:** More sophisticated microgrids must be able to curtail power incrementally. The size of the increments is dependent on the dispatch. The Advanced Battery Valuation strategy assumes that the energy management system will be able to curtail by any amount of power.

4.6.2 Energy Balance

In each hour, LREM meets the expected load by dispatching resources in accordance to the chosen operational strategy. The network is assumed to be a single node model by simplifying demand into a single aggregated value in each hour. The total available PV power in each hour is calculated by multiplying the PVWatts values (which represent the hourly DC outputs of a 1 kW PV array) by the total PV bank size. Naturally, PV power is non-dispatchable.

Per LREM’s sign convention, if the battery is charging (net battery power is positive) the following energy balance must hold. In this case, the ICE may be on, indicating that there is power from the AC bus entering the DC bus, or the battery may be charged directly by the PV panels.

$$0 = P_{\text{battery_in}}(\mathbf{t}) - P_{\text{battery_out}}(\mathbf{t}) - P_{\text{pv}}(\mathbf{t}) + P_{\text{DC_dissipated}}(\mathbf{t}) - [P_{\text{gen}}(\mathbf{t}) + P_{\text{unmet}}(\mathbf{t}) - P_{\text{load}}(\mathbf{t}) - P_{\text{AC_dissipated}}] * \eta_{\text{rect}}$$

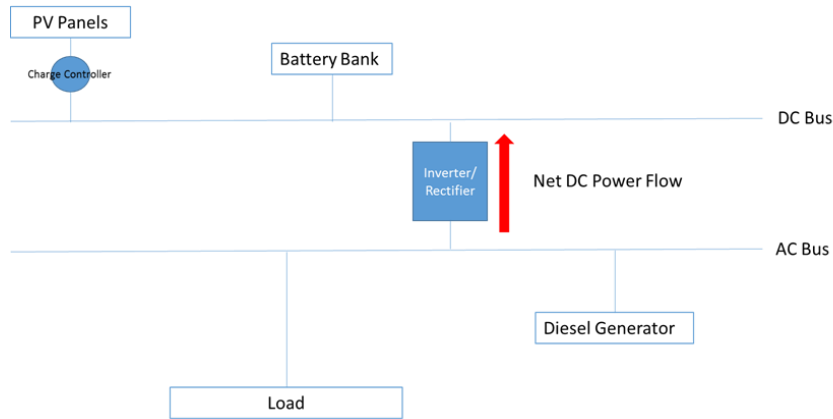

Figure 9. Net DC power flow across the inverter towards the DC bus

If the battery is discharging to meet the load (net battery power is negative), then the net DC flow should be towards the AC bus and the following energy balance must hold:

$$0 = [P_{\text{battery_in}}(t) - P_{\text{battery_out}}(t) - P_{\text{pv}}(t) + P_{\text{DC_dissipated}}(t)] * \eta_{\text{inv}} - [P_{\text{gen}}(t) + P_{\text{unmet}}(t) - P_{\text{load}}(t) - P_{\text{AC_dissipated}}]$$

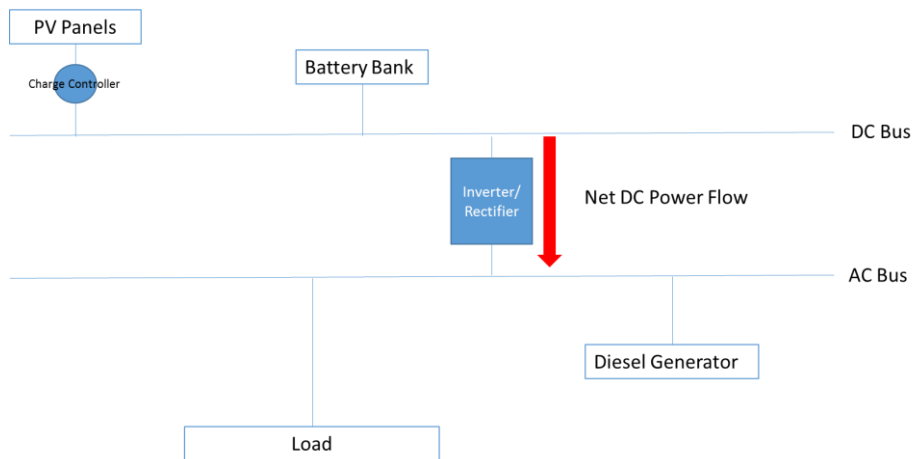

Figure 10. Net DC power flow across the inverter towards the AC bus

The operational strategies respect this fundamental energy balance in the computation of hourly dispatch. The following subsection provides a qualitative summary of each operational strategy available in LREM. Accompanying algorithmic descriptions are provided in flow chart form in the Appendix.

4.6.3 The Simplest DC Strategy

The Simplest DC strategy assumes a completely DC system operated in the most basic manner. This strategy represents the “bare-bones” method of operation. It assumes the only available assets are solar resources and storage, and requires DC electricity demand, eliminating the need for an inverter and AC bus. In each hour, the demand is first met with PV resources. Excess energy is stored in the battery within the battery input limits defined by the KiBaM. If the PV is not enough to meet the load, then the battery is dispatched. Figure 11 provides an example of hourly dispatch run with the Simplest DC strategy

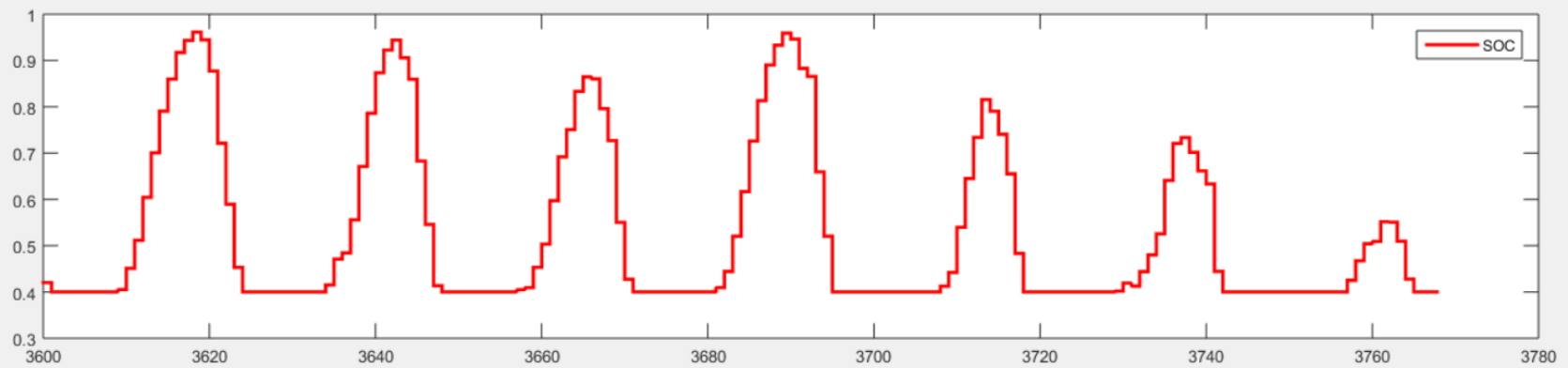
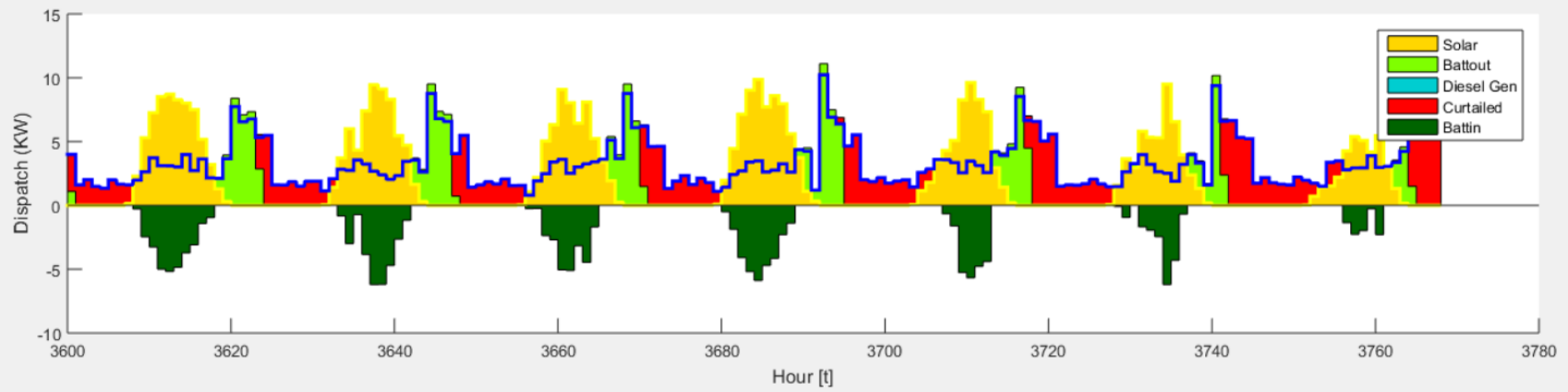

Figure 11. An example of hourly dispatch run with the Simplest DC strategy

4.6.4 The Cycle Charge Strategy

The Cycle Charge strategy (described by Barley et al. (1993)) offers one method to deal with the uncertainty of renewable resource availability. Given that the system cannot consider the resource forecast, an operator faces the uncertainty of whether the battery will run out of energy in the near future. The Cycle Charging strategy manages this risk by charging the battery with excess energy from the ICE, strategically. In doing so, it assumes the risk of excessively charging the battery with diesel and spilling solar power in future hours. Specifically, if the ICE is on and the battery is below a set threshold, the system chooses to run the diesel at maximum power (taking advantage of the higher efficiency) until the state of charge (SOC) reaches that threshold. A summary of the logic is as follows:

- 1) In each hour, the power limits of the battery are calculated. KiBaM dictates the max power that can be charged and discharged within each hour.
- 2) The ICE operational constraint is first considered: if the SOC is below the threshold and the ICE was on in the previous time period, then the ICE stays on at maximum power in the next time period.
- 3) If the ICE is on for operational reasons, then:
 - a. The energy balance is calculated given the availability of renewable resources and the ICE power
 - b. If extra power is needed, it is met by the battery. If the additional power needed exceeds the power output of the battery, there will be unmet energy.
- 4) If the ICE is not on for operational reasons, then:
 - a. The ICE is assumed to be off. The Cycle Charge dispatch prioritizes battery usage over diesel usage. The power needed from the battery is calculated given the availability of renewable resources.
 - b. If possible, the demand is met with the battery.
 - c. If excess power is needed, it is met by the ICE. If the additional power needed is below the minimum power of the ICE, the ICE turns on at the minimum. If the demand needed exceeds the maximum power output of the ICE, there will be unmet energy.
- 5) The excess power is used to calculate the energy inputted into the battery during the hour. The limits of power that can be charged into the battery are defined by the KiBaM.

The Cycle Charge strategy is unable to choose to curtail power. Thus, the unmet energy only arises when the system is physically unable to meet demand. An example of hourly dispatch run with the Cycle Charge strategy is shown below.

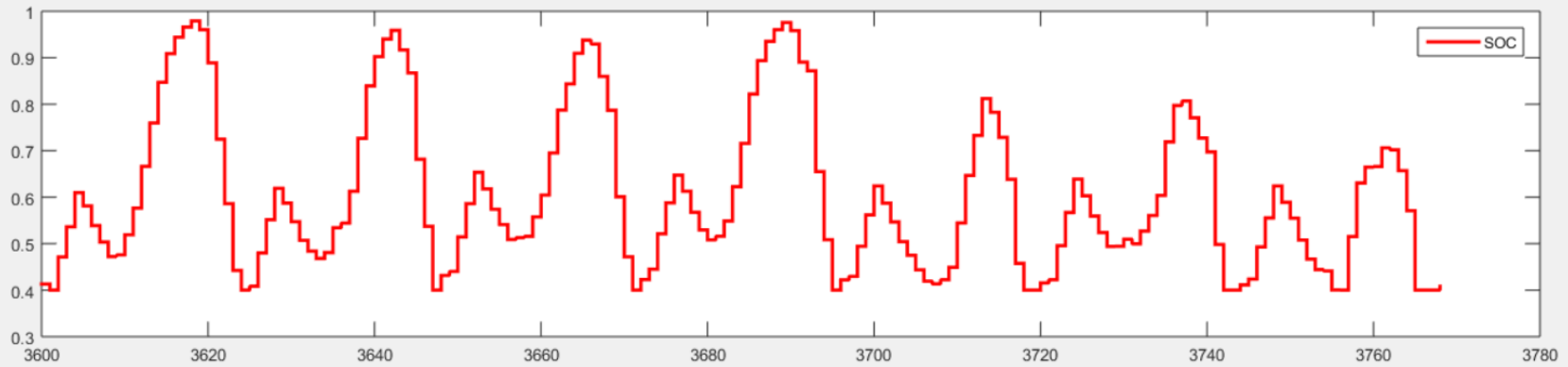
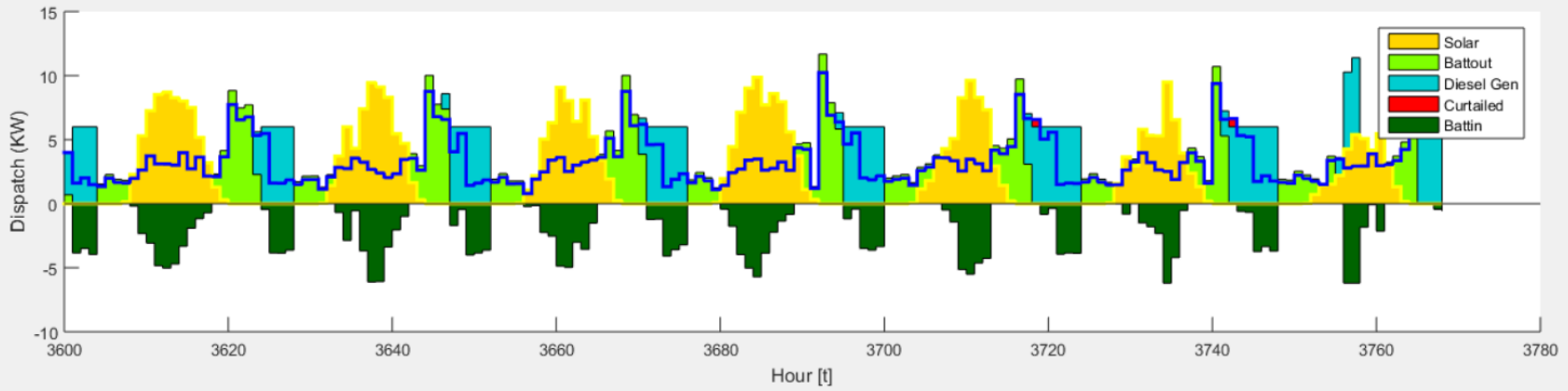

Figure 12. An example of hourly dispatch run with the Cycle Charge strategy

4.6.5 The Load Following Strategy

The Load Following strategy (also discussed in Barley et al. (1993)) limits the usage of the ICE to charge the battery. When diesel is needed, it simply follows the load. The only instance in which diesel is used towards battery charging is when the energy needed to be met by the ICE is below the minimum power limit. In this situation, the diesel is turned on at the minimum power limit and extra energy is stored in the battery, if possible.

The Load Following logic is very similar to the cycle charging logic. The only difference in the function is that ICE operational constraints have been removed:

- 1) In each hour, the power limits of the battery are calculated. KiBaM dictates the max power that can be charged and discharged within each hour.
- 2) Assuming that ICE is not on:
 - a. The power needed from the battery given the available solar resources is calculated. If additional power from the battery is needed, the dispatch prioritizes battery usage over diesel usage. If possible, the demand is met with the battery.
 - b. If excess power is needed, it is met by the ICE. If the additional power needed is below the minimum power of the ICE, the ICE turns on at the minimum. If the demand needed exceeds the maximum power output of the ICE, there will be unmet energy.
 - c. Excess power is calculated.
- 3) The amount of battery charge is calculated, given the excess power and KiBaM limits.

Load following is similarly unable to choose to curtail power. An example of the hourly dispatch run with the Load Following strategy is provided in Figure 13.

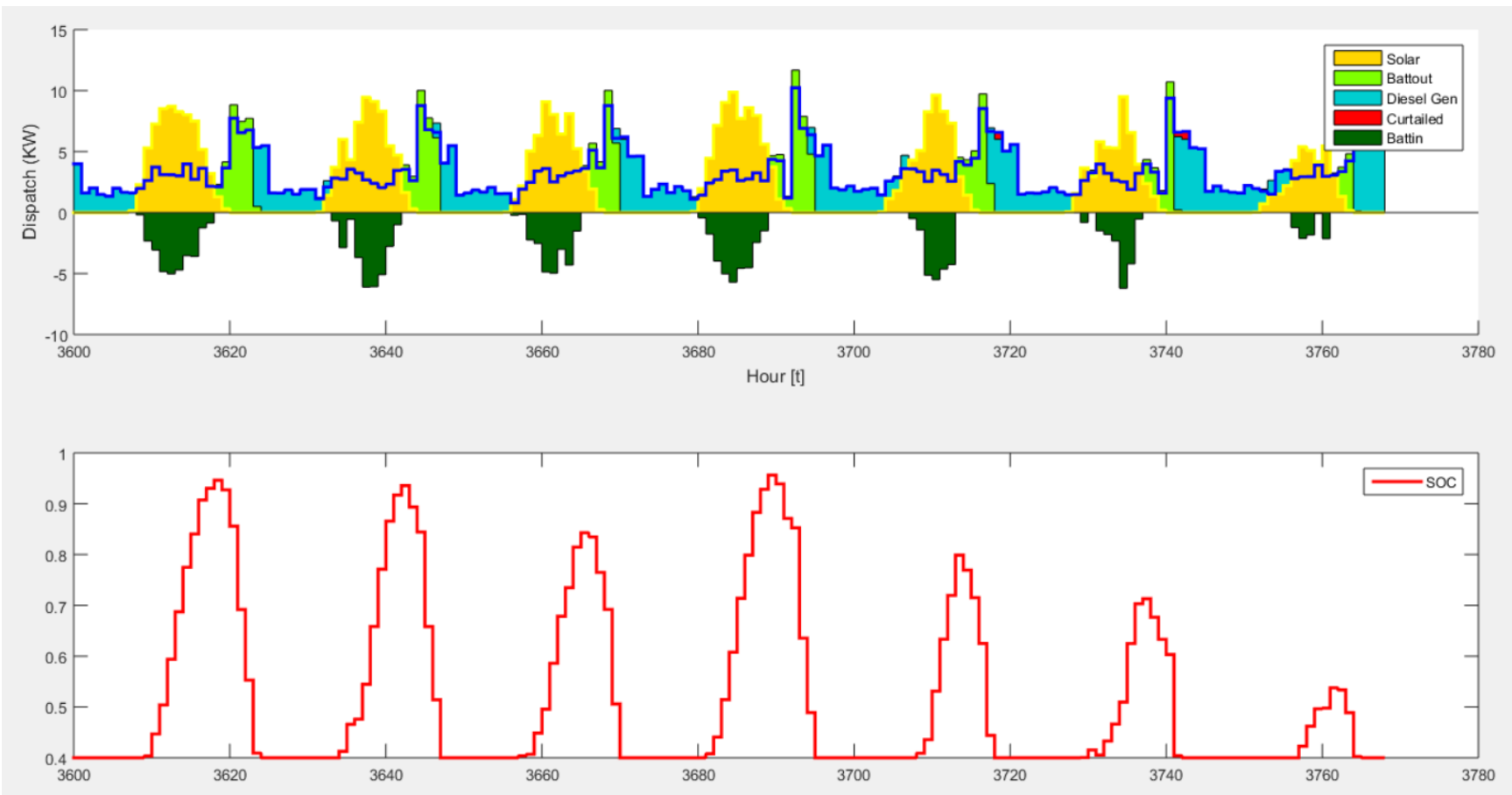

Figure 13. An example of hourly dispatch resulting from the Load Following strategy

4.6.6 The Forward Looking Cycle Charge Strategy

The weakness of the Load Following and Cycle Charge strategies is the inability to foresee the future availability of renewable resources when choosing the dispatch of each current hour. Adding forecast capability attempts to overcome this challenge by allowing the system to choose to charge the battery with excess diesel energy *only when the next period of solar resources is scarce*. This is an attempt to avoid the problem that the Cycle Charge strategy faces, which is the excessive use of diesel for charging the battery, resulting in spilled solar in future hours.

Specifically, in its consideration of the ICE operational constraint, the Forward Looking Cycle Charge strategy first determines the next period of solar insolation. It then calls on an internal Cycle Charge strategy and iterates only through the hours associated with the day containing the next period of insolation. The simultaneous concurrences of spilled energy and PV availability in excess of load is tallied in the next period. If the tally exceeds n (defined by the user as the threshold), the ICE will not be run at maximum power, *even if the battery is below the threshold and the ICE was on previously*. In short, the decision of whether the ICE should be run in excess is now subject to a third restraint – the presence of excess solar insolation. The rest of the logic remains the same. An example of hourly dispatch resulting from the Forward Looking Cycle Charge strategy is presented in Figure 14.

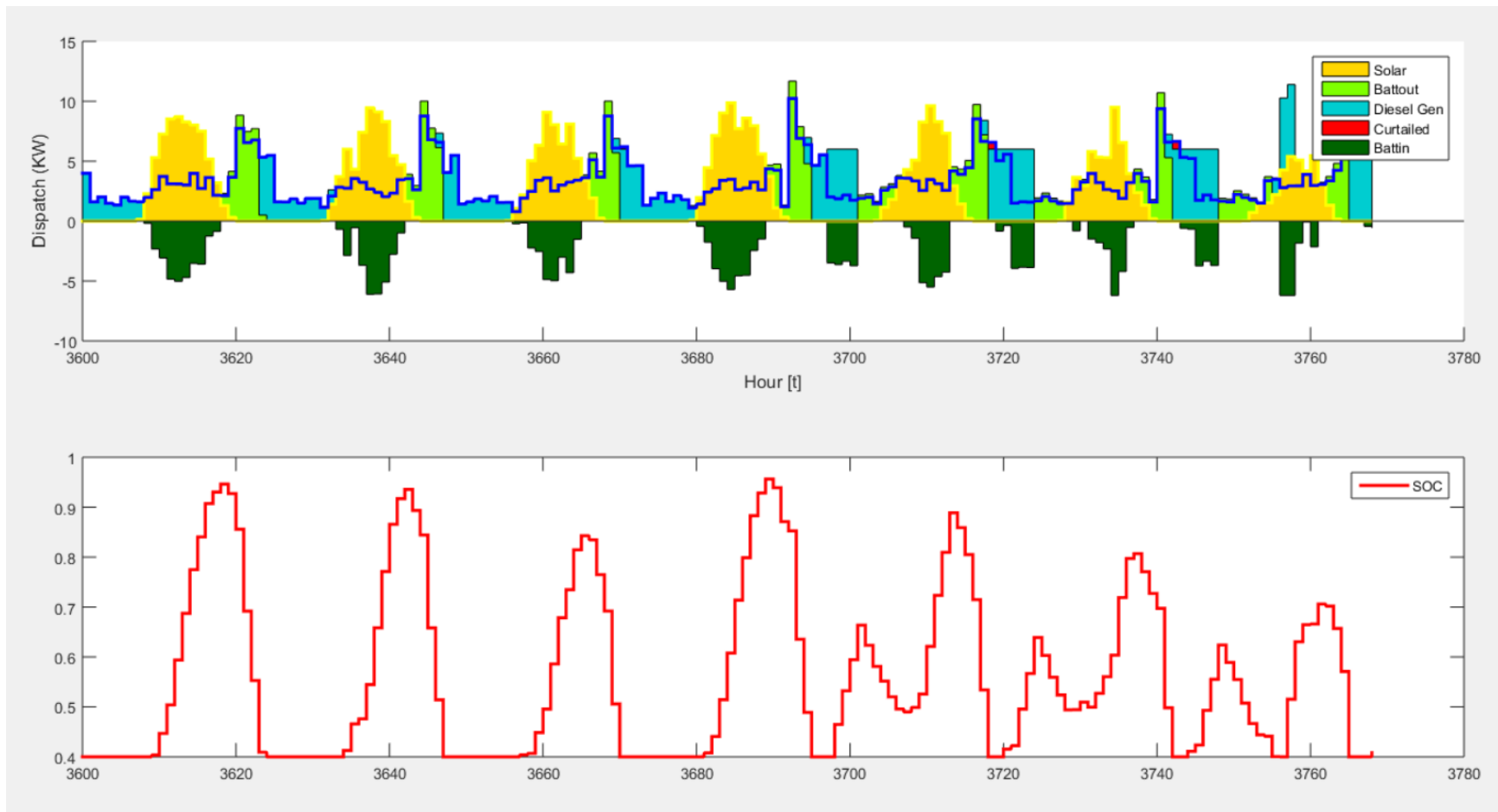

Figure 14. An example of hourly dispatch resulting from the Forward Looking Cycle Charge Strategy

4.6.7 The Advanced Battery Valuation Strategy

The Advanced Battery strategy embodies three major capabilities that improve its decision-making.

1. The Advanced Battery strategy allows for demand to be categorized as either critical or non-critical, where critical demand is valued more. The cost associated with curtailing it is greater than that of non-critical demand.
2. Unlike the Cycle Charge and Load Following strategies, Advanced Battery strategy assumes the system is capable of making the conscious decision to curtail by any amount of energy. If it makes economic sense to do so. In this way, it treats non-served energy as a generator. For the Advanced Battery strategy, the available resources are: solar, ICE, curtailed demand (critical and non-critical), and battery output.
3. The hourly battery value accounts for the opportunity costs of using the battery. The value of the battery is a function of the state of charge (SOC) relative to the value of all other resources including curtailment. It is further adjusted to account for degradation costs. The battery becomes more valuable as its SOC decreases. As SOC increases, LREM find it more preferable to dispatch the battery ahead of more expensive resources. The decision to charge the battery follows similar logic. Resources are used to charge the battery if the resource cost (including battery degradation) is below the opportunity cost of the battery.

It should be noted that this dispatch strategy is idealized, by which is meant that the software hardware to implement the needed control may not be available in standard equipment. The Advanced Battery strategy assumes that the microgrid system will be able to implement the capabilities it assumes. The operational logic is as follows:

- 1) In each hour, the resources are ranked by cost then dispatched accordingly, with the least expensive dispatched first until the demand (and losses from the battery, controller, inverter and grid) is met.
- 2) The decision to charge the battery with remaining resources is made. Starting with the one of least cost and until the battery's max power input is met, resources are used to charge the battery only if the resource cost is (including battery degradation cost) is less than the opportunity costs of the battery. In Figure 15, the empty space below the PV insolation line depicts the solar power that was not used to charge the battery.

An example of the hourly dispatch run with the Advanced Battery Valuation strategy is presented in Figure 15.

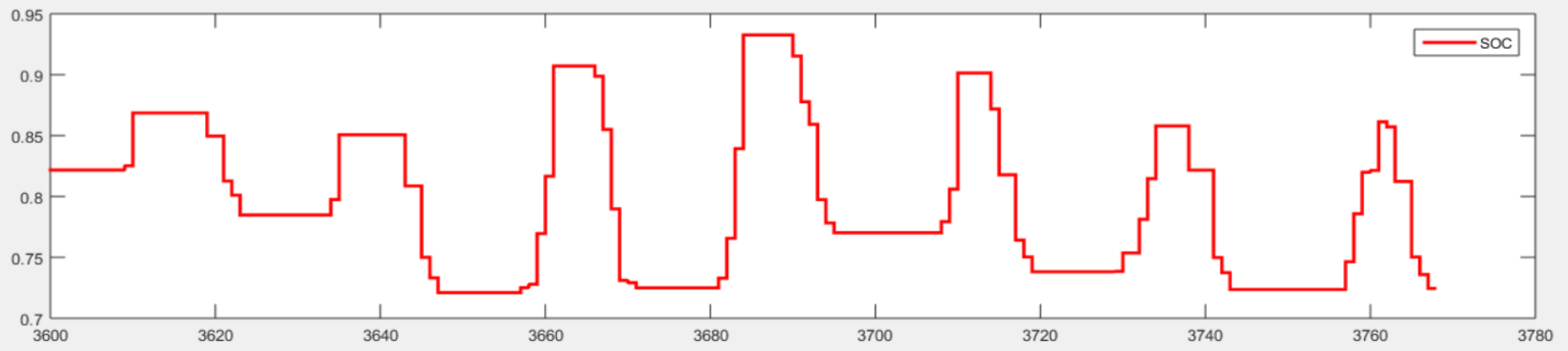
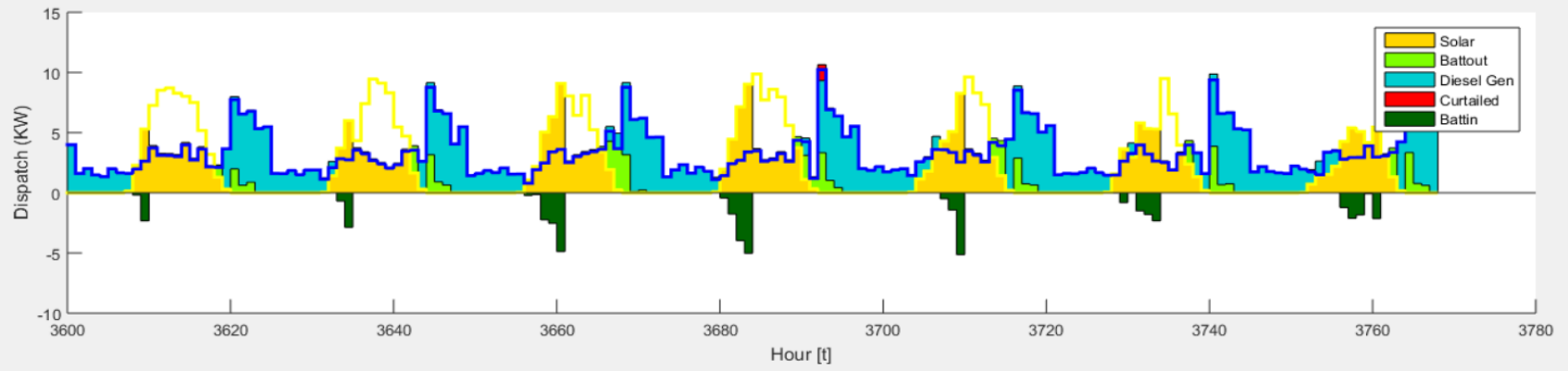

Figure 15. An example of hourly dispatch produced from the Advanced Battery Valuation strategy

4.7 Technical Management Needs

The technical operations of a microgrid rely on physical equipment or software to be physically implemented. As the operational sophistication of a microgrid increases, the suite of hardware also must increase in technical sophistication. Capital is thus expected to increase as well. Figure 16 depicts the increasing complexity in hardware necessitated by increasingly sophisticated operational strategies.

- The Simplest DC strategy requires the least amount of management equipment. If desired, an operator of a Simplest DC strategy based system may choose not to rely on physical management capabilities at all. In doing so, the operator assumes that users will abide by contracted terms. For example, the operator might assume that consumers will use only approved appliances and will only consume power at designated hours.
- On the other hand, the operator of a Simplest DC microgrid may choose to implement physical hardware to ensure operational success. A breaker can connect or disconnect the load and can ensure that users cannot consume power outside of hours. Devices for capacity and volumetric control, such as current limiters or meters, can be used to enforce compliance with appliance limits and consumption terms. In doing so, the management hardware moves towards Column 2.
- The Load Following and Cycle Charging strategies require an inverter to manage power transfer between the AC and DC buses. A battery monitoring device is also needed for the operator to know when the ICE should be turned on (either manually or automatically). More advanced systems could implement a signal system to elicit demand responses. The management devices of this category allow the system to sense its current state and react appropriately.
- Moving towards the right to the third column, operational strategies which do not function on set rules have dispatch patterns that are not fixed. As such, the system will need to be able to execute hourly dispatches that do not follow a programmable pattern. Thus, the management hardware of Column 3 must be more sophisticated because it must be able to react to dispatch appropriately.
- Mathematical programming based operational strategies will require additional software capable of solving optimization problems. Thus, Column 4 requires management devices with this capability.
- Predictive operational strategies will need to acquire forecast data, which is typically purchased from suppliers who generate it. These systems must be able to receive forecast data either automatically or manually.

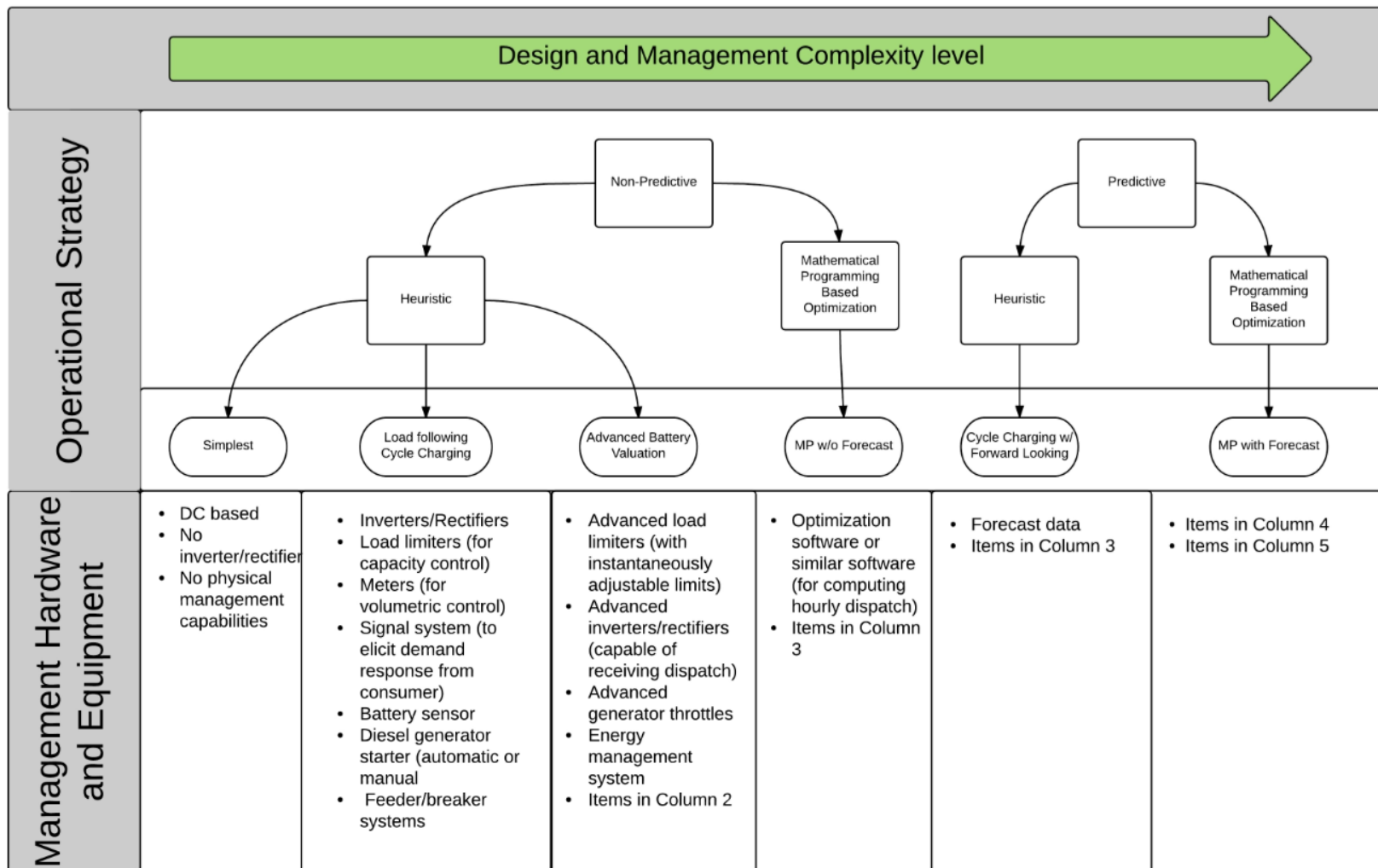

Figure 16. Management hardware and equipment needs in relation to a spectrum of operational strategies

Chapter 5: Scenario Analysis with LREM: A Demonstrative Exercise

5.1 Overview

LREM's strongest asset is its ability to be used for the exploration of financial, technical, and performance implications of various factors. Specifically, developers may be interested in using the model to:

- Choose the consumer base that best fits within the budgets of the project
- Determine the tariff rate needed to meet running costs, recover capital, or both
- Understand the financial implications of limiting diesel consumption
- Estimate the expected service reliability
- Ascertain the dispatch method most suitable for the expected demand scenario
- Decide on the location of the generation site
- Determine the optimal set of generation investment given the expected demand curve

For demonstrative purposes, I walk through a case study of the village of Karambi in Rwanda to elucidate the process of applying LREM and to illustrate the resulting outputs. In this exercise, the factor under consideration is the location of the generation site for the Karambi pilot project. The spatial configuration of the consumers in Karambi is unusual; buildings are stretched across approximately 1 km of land, following the main road. Given this unfavorable spread, the location of the generation resources could substantially affect the network design.

LREM can aid in this decision by providing relevant financial estimates of the following two scenarios, in which everything is held constant but the generation site:

Case 1: The generation assets are located at the hospital

Case 2: The generation assets are located at the original site of the central field.

An uncomplicated example is intentionally chosen to ensure the implications are clear in this case study.

5.2 Karambi Village

Karambi, shown in Figure 17, is a village located around an hour north of Kigali, Rwanda by car. The community, currently entirely without access to electricity, is agricultural based and situated on the top of a hill. The subset of the village identified for the pilot microgrid consists of 199 total buildings surrounding two schools and consists of 10 consumer types:

- 1) 176 residential homes
- 2) 1 high school
- 3) 1 primary school
- 4) 1 health center
- 5) 1 bank
- 6) 1 government building
- 7) 1 coop
- 8) 9 small shops

The building locations were located via GPS coordinates taken electronically by hand during site visits by the research team. The set of coordinates for each type of consumer must be inputted in the form of .kml files.

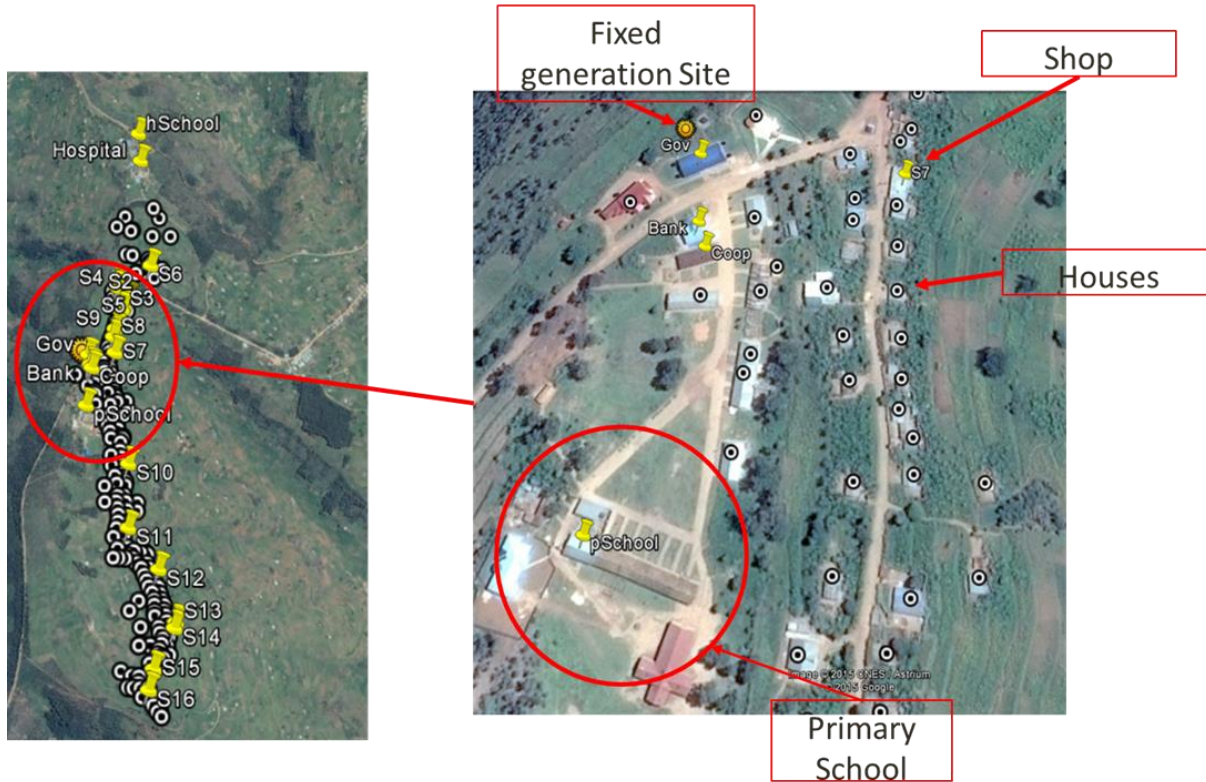

Figure 17. An arial view of Karambi village

The oblong configuration of the village can be seen in Figure 17. Houses follows the main road with the furthest most buildings approximately 1 kilometer in distance apart. The field location for the generation site is marked by the sun icon. It is centrally located near the center of the strip of demand nodes. The second option would place the generation site at the hospital located near the northern tip.

To gauge demand, an extensive survey, the subject of Santos-Pérez (2015), was developed and applied with the help of local engineering students¹³. Results from the survey estimated the appliance sets, hours during which appliances would likely be used, and the number of appliances for each type of consumer. This information was inputted into the demand inputs template of LREM and used to construct estimates of the hourly demand profile for each type of consumer in Figure 18. The aggregate load is shown in Figure 19¹⁴.

The resulting demand profile exhibits slight differences in demand across the days to represent the variation in demand that is seen in reality. Demand also tends to differ throughout the year due to seasonal changes in daylight hours and temperature. Furthermore, the load curve indicates that demand peaks in the evening, when lighting is required. When the demand profiles of each consumer type is plotted, the resulting plots differ considerably in shape and peak. Table 2 summarizes the demand

¹³ This is the subject of the PhD dissertation of Javier Santos-Pérez, 2015, Comillas University

¹⁴ As an aside, the survey depicts the ultimate aspirations of each type of consumer, but these values may not be realistic. Appliances may be too expensive or the energy requirements may be unaffordable.

expected in Karambi. The aggregated peak annual demand of the entire system is expected to be approximately 28 kW.

Table 2. Summary of demand

kW or kWh	Adv Res	Basic Res	Prim School	High School	Coop	Bank	Med Center	Govertment	Church	shopes
Customer Type	1	2	3	4	5	6	7	8	9	10
Peak of Customer Type	0.234	0.047	0.64	1.551	0.037	1.095	4.241	1.565	1.707	0.235
Annual Energy Consumption (Each)	351.3376	87.7076	1194.199	6114.5096	122.527	4133.298	8981.98	3463.616	4285.8374	324.887
Peak of Aggregate	28.088									

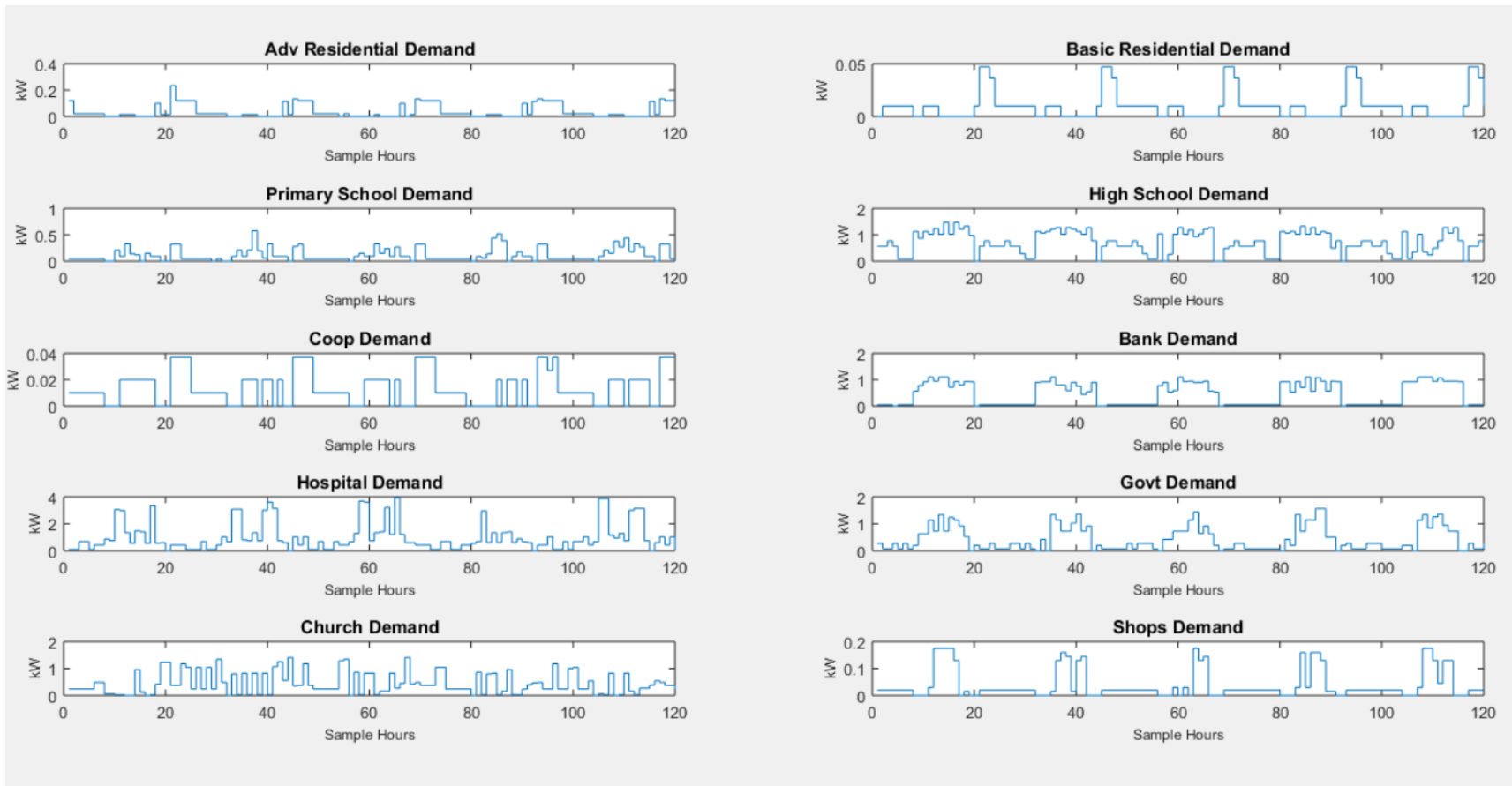

Figure 18. The demand profiles of each consumer type

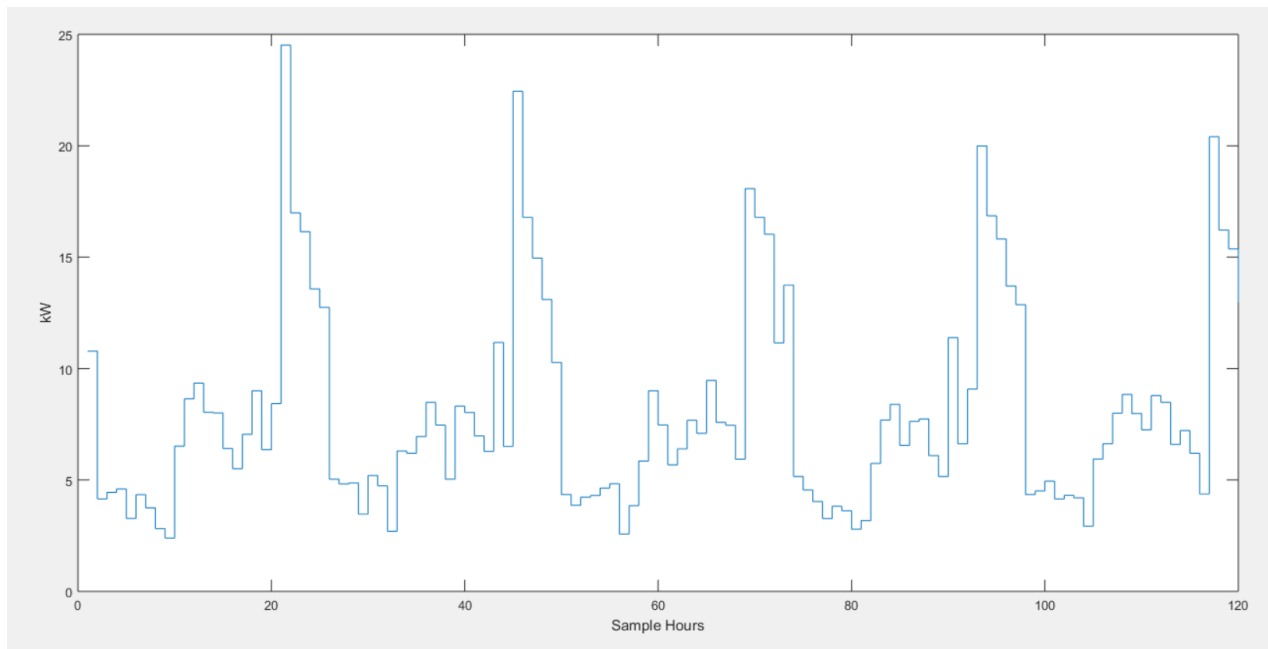

Figure 19. The hourly aggregate demand profile of Karambi

The same inputs can be used to run LREM with any of the available operational strategies. For this case study, the Load Following strategy was used in both scenario runs.

5.3 Inputs

The values in the following tables represent the best collection of Rwandan costs. Where local data was unavailable, values were estimated from online suppliers or via discussions with Indian microgrid developers. It is expected that the user of LREM should have more accurate data and unhindered access to local market information. General cost assumptions and calculations were discussed in Chapter 3.

5.3.1 Labor:

By default, LREM calculates labor by associating each generation asset to annual man hours needed. Another approach is to account for labor only in the final post processing step of the financial analysis simply as annual worker salaries. In the case of Karambi, the second option is pursued. Discussion with local entrepreneurs indicate that developers often hire a number of workers to handle O&M for the entire microgrid project¹⁵.

5.3.2 Inverter/Rectifier

The generation catalog includes multiple sizes of inverters and rectifiers, along with their associated costs (Table 3). Recall, the inverter/rectifier is sized to meet peak demand. In lieu of local data, inverter sizes and costs were based on representative values identified in a survey of wholesalesolar.com discussed in detail in Ellman (2015). Briefly:

- Inverter costs differ substantially based on inverter features and capabilities including “the range of control options, efficiency, warranty, and interoperability with other systems” (Ellman, 2015). Nonetheless, the general finding was that inverters/rectifiers tend to see economies of scale and

¹⁵ This is the reason why the Annual O&M related fields are inputted as “0” in the generation catalog tables.

larger sizes are less expensive in terms of \$/kW than smaller sizes. The inverters selected were the ones of least cost for a variety of sizes.

- The smallest size selected was the smallest inverter identified in the survey
- The inverter/rectifier efficiencies are assumed to be constants across all power ranges.

Table 3. Invertors available in the generation catalog and their parameters

Costs (\$/kW)	927	740	600	543	364	319	260	220	190	190
Sizes (kW)	0.15	0.2	0.25	0.3	1	1.5	5	6	10	11.4
Min Size (kW)	0.15									
Life (years)	15									
Inverter Efficiency (p.u.)	0.95									
Rectifier Efficiency (p.u.)	0.95									
Rectifier Capacity / Inverter Capacity Ratio	0.8									
Installation Costs as fraction of converter cost	0									
Annual O&M as a fraction of converter cost	0									
Annual O&M man-hours	0									

5.3.3 Charge Controller

Similarly, the generation catalog includes multiple sizes of charge controllers and their associated costs (Table 4). The charge controller is assumed to have minimal economies of scale and is estimated based on data provided by the contact with an Indian developer. This is why the prices shown do not vary amongst controllers of varying sizes. Ellman (2015) notes that charge controller costs are particularly difficult to estimate based on size, because the prices vary substantially with the available features of the product.

Table 4. Charge controllers available in the generation catalog and their parameters

Costs (\$/kW)	200	200	200	200	200	200
Sizes (kW)	0.054	0.12	0.24	1.44	3.84	4.13
Min Size (kW)	0.054					
Life (years)	15					
Efficiency (p.u.)	0.95					
Installation Costs as fraction of charge controller cost	0					
Annual O&M as a fraction of charge controller cost	0					
Annual O&M man-hours	0					

5.3.4 PV Panels

Available PV panel parameters are inputted per unit size. In Rwanda, a single 250 W panel unit is estimated to cost \$225 (see Table 5) based on estimates of local prices provided by Rwandan developers. Recall that PV units are added incrementally to compose an entire PV bank.

Table 5. The PV panel available in the generation catalog and its parameters

Size (kW)	Cost (\$)	Life (years)	Installation Costs as fraction of panel cost	Annual O&M as a fraction of panel cost	Annual O&M man-hours
0.25	225	15	0	0	0

5.3.5 Battery

The battery is assumed to be a flooded lead acid (chosen for its affordability). Costs were estimated based on average local costs provided by a Rwandan developer. The values presented in Table 6 represent per unit battery parameters. LREM builds the battery bank as multiples of that unit.

Table 6. The battery unit available in the generation catalog and its parameters

Battery Type	Cost (\$)	SOC (p.u.)	Initial	Capacity at end of life (fraction of nameplate energy capacity)	Installation Costs as fraction of battery cost	Annual O&M as a fraction of battery cost	Annual O&M man-hours
TROJ_T105	213.9	0.5		0.7	0	0	0

Battery	energy	SOC min	SOC max	Q max	Efficiency	alpha _c	I charge max	I discharge max	Nominal V	Lifetime Throughput	c	k
Units	kWh	(p.u.)	(p.u.)	kWh	(p.u.)	A/Ah	A	A	V	kWh	(p.u.)	1/hr
TROJ_T105	1.38	0.4	1	1.38	0.92	1	28.75	57.5	6	1104	0.28	1.85

5.3.6 The Internal Combustion Engine (ICE)

Costs were also estimated based on data provided by contacts in India. ICEs below 6 kW capable of automatic control are very rarely seen in their experience; the smallest size is therefore set to 6 kW. ICEs are more efficient when producing near full load and less efficient as they approach their minimum power output. Efficiency also increases as ICE size increases. Operation below the minimum power rating is discouraged. Start-up fuel is assumed to be negligible for small ICE sizes of the range presented in Table 7.

Table 7. The ICEs available in the generation catalog and their parameters

Generator Size (kW)	1/4 Load (l/kWh)	1/2 Load (l/kWh)	3/4 Load (l/kWh)	Full Load (l/kWh)	No-load (l/h)	Minimum power	Lifetime (h)	Cost (USD)	Maintenance (USD/year)	Startup fuel (l)
0	0.00	0.00	0.00	0.00	0.00	0.00	0.00	0.00	0.00	0.00
6	0.39	0.35	0.32	0.30	0.00	1.20	7300.00	1920.00	0.00	0.00
8	0.36	0.31	0.29	0.27	0.00	1.60	7300.00	2471.28	0.00	0.00
10	0.34	0.30	0.28	0.26	0.00	2.00	7300.00	2785.91	0.00	0.00
15	0.34	0.30	0.28	0.26	0.00	3.00	7300.00	3463.66	0.00	0.00
20	0.34	0.30	0.28	0.26	0.00	4.00	7300.00	4042.34	0.00	0.00
25	0.34	0.30	0.28	0.26	0.00	5.00	7300.00	4556.98	0.00	0.00

Generator Size (kW)	1/4 Load (l/kWh)	1/2 Load (l/kWh)	3/4 Load (l/kWh)	Full Load (l/kWh)	No-load (l/h)	Minimum power	Lifetime (h)	Cost (USD)	Maintenance (USD/year)	Startup fuel (l)
30	0.34	0.30	0.28	0.26	0.00	6.00	7300.00	5025.75	0.00	0.00
40	0.34	0.30	0.28	0.26	0.00	8.00	7300.00	5865.41	0.00	0.00
60	0.34	0.30	0.28	0.26	0.00	12.00	7300.00	7292.34	0.00	0.00
80	0.34	0.30	0.28	0.26	0.00	16.00	7300.00	8510.68	0.00	0.00

5.3.7 Settings:

The settings file holds cost related inputs unrelated to the generation catalog. Most notable are the CNSE, the diesel price, and the network lifetime. Diesel prices in Karambi are near \$2/L when transportation is considered. The dispatch assumes 5% power loss in the distribution system. The actual distribution losses are calculated in RNM, which is decoupled from the dispatch decision. The network lifetime is assumed to be 25 years.

5.3.8 Network Catalog

The set of available low voltage wires and medium voltage/low voltage transformers is shown in Tables 8 and 9. Technical parameters are needed for each component.

Table 8. The low voltage wires available in the network catalog

Name	Resistance (ohm/km)	Reactance (ohm/km)	Rated Current (per unit)	Overload (per unit)	Min Failure Rate (failures/(km*a))	Max Failure Rate (failures/(km*a))	Average failure rate (failures/(km*a))	Overnight costs (\$)	Preventative Maintenance Costs (\$/year*km))	Corrective Maintenance Coss (\$/failure)
Mole_s	20.37	1.58	22.00	1.2	0.133	0.133	0.133	990	2.8	427
Gopher_s	8.41	1.41	38.33	1.2	0.133	0.133	0.133	1920	2.8	427
Weasel_s	6.99	1.38	43.00	1.2	0.133	0.133	0.133	2230	2.8	427
Ferret_s	5.21	1.32	51.67	1.2	0.133	0.133	0.133	2850	2.8	427
Weasel	1.16	0.23	129.00	1.2	0.133	0.133	0.133	3346	2.8	427
Ferret	0.87	0.22	155.00	1.2	0.133	0.133	0.133	4338	2.8	427
Rabbit	0.70	0.21	178.00	1.2	0.133	0.133	0.133	5330	2.8	427
Horse	0.50	0.19	225.00	1.2	0.133	0.133	0.133	7314	2.8	427
Dog	0.35	0.19	271.00	1.2	0.133	0.133	0.133	10290	2.8	427
Dingo	0.23	0.18	346.00	1.2	0.133	0.133	0.133	15250	2.8	427
Lynex	0.20	0.17	384.00	1.2	0.133	0.133	0.133	17730	2.8	427
Jaguar	0.18	0.17	411.00	1.2	0.133	0.133	0.133	20210	2.8	427
Panther	0.17	0.17	420.00	1.2	0.133	0.133	0.133	20210	2.8	427
Zebra	0.09	0.15	636.00	1.2	0.133	0.133	0.133	40050	2.8	427

Table 9. The medium voltage /low voltage transformers available in the network catalog

Name	Installed Power Capacity (kVA)	Guaranteed Power Capacity (kVA)	Voltage	No Load Losses (kW)	Resistance on the Lower side of the Transformer (ohms)	Max Num of Output Ports	Investment Cost per Port (\$/port)	Failure Rate Min (failures/year)	Failure Rate Med (failures/year)	Failure Rate Max (Failures/Year)	Investment Costs (\$)	Preventative Maintenance Costs (\$/Year)	Corrective Maintenance Costs (\$/failure)
CTI0_V	10	10	11	0.1	0.6	2	0	0.007	0.007	0.007	2400	230	1500
CTI1_V	16	16	11	0.124	0.4	2	0	0.007	0.007	0.007	2640	230	1500
CTI2_V	25	25	11	0.136	0.3	2	0	0.007	0.007	0.007	3000	230	1500
CTI3_V	40	40	11	0.15	0.08	2	0	0.007	0.007	0.007	3600	230	1500
CTI4_V	63	63	11	0.262	0.045	2	0	0.007	0.007	0.007	4520	230	1500
CTI5_V	100	100	11	0.381	0.035	2	0	0.007	0.007	0.007	6000	230	1500
CTI6_V	200	200	11	0.577	0.01	2	0	0.007	0.007	0.007	10000	230	1500

5.4 Demonstrative Results

The results obtained in this study are shown and discussed in the subsequent subsections.

5.4.1 Network Design

Figure 20 provides a visual representation of the differences in optimal network configuration between the two options. If the generation site is placed at the medical center, the distance between the majority of the demand nodes and the generation site increases. More lines are needed to maintain optimal power flows and to prevent significant voltage decreases.

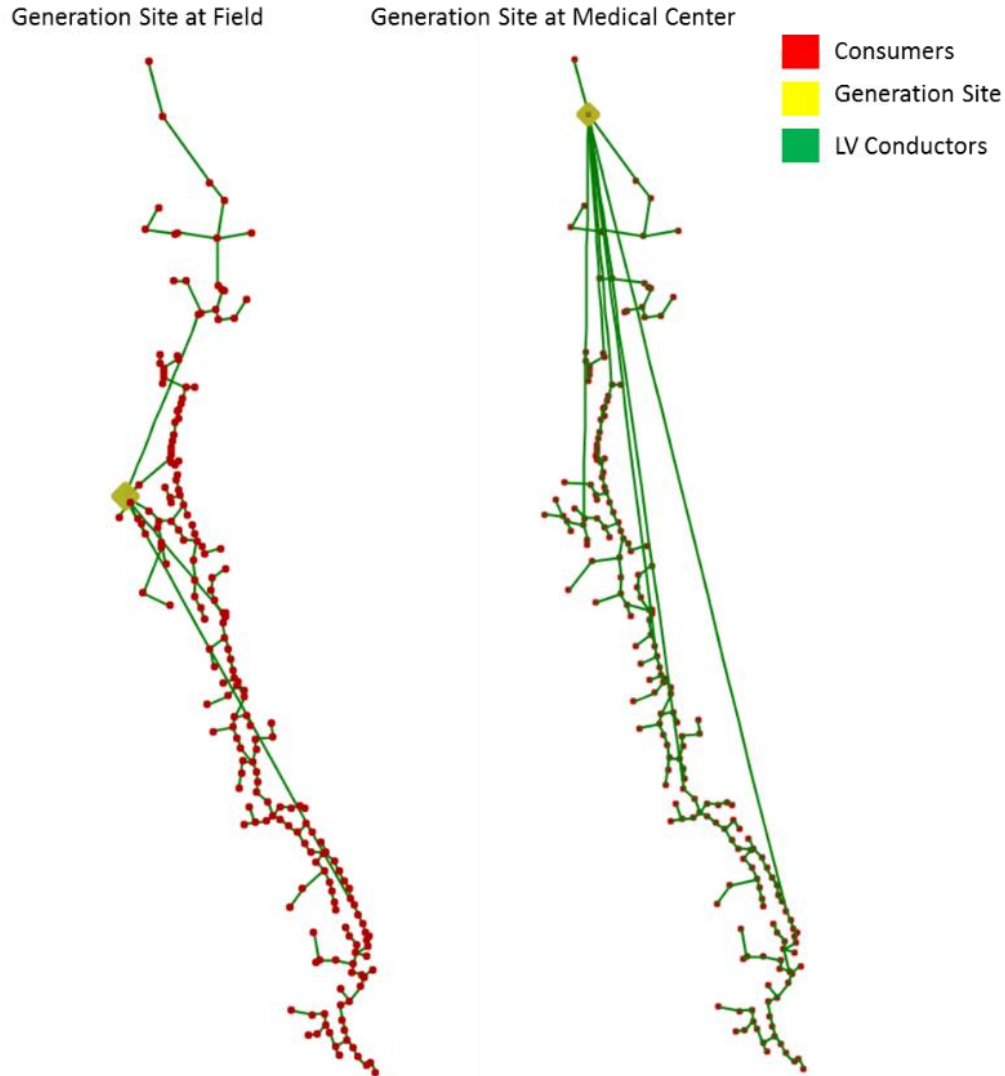

Figure 20. The resulting network designs given the generation site locations

Besides shape files, the RNM outputs also detail the spatial coordinates of the each length of conductor, as well as the specific conductor type and parameters of each length. Tables 10 and 11 summarize the results. From these summary tables, we see that placing the generation site at the hospital requires far more conductor length than if the generation site were placed on the centralized field. In both cases, only a low voltage network was needed.

Table 10. Generation Site at Hospital

Network Voltage	Name	kVA	I/I _{max} (per unit)	Length (km)	Investment Costs
Low	Mole (single phase)	15	0.04	5.08	5024
Low	Gopher (single phase)	27	0.11	0.46	886
Low	Weasel (single phase)	30	0.13	0.11	239

Low	Weasel	89	0.10	1.39	4650
Low	Ferret	107	0.14	3.28	14243
Low	Rabbit	123	0.06	1.51	8058
Low	Dog	188	0.1	0.6	6197

Table 11. Generation Site at Field

Network Voltage	Name	kVA	l/lmax (per unit)	Length (km)	Investment Costs (\$)
Low	Mole (single phase)	15	0.04	4.37	4326
Low	Gopher (single phase)	27	0.11	0.52	990
Low	Weasel (single phase)	30	0.13	0.18	399
Low	Weasel	89	0.10	2.10	7026
Low	Ferret	107	0.14	0.15	638
Low	Horse	156	0.13	0.34	2479

5.4.2 Generation Set (kW)

The optimal generation mix found in the generation search (run with the Load Followig strategy) is the same in both cases. This is expected, given that the total demand is unchanged from one case to the next.

Solar Capacity (kW)	Storage Capacity (kWh)	Genset Capacity (kW)
57.24	264.96	8

Sample hours of the expected dispatch is shown in Figure 21. Solar is sized to cover day time load and provide additional energy for storage. At \$2/L, the diesel price is found to be less economical than the battery storage. The dispatch shows that the operational strategy prefers to meet night time load with battery power. The ICE only serves load when the battery nears its minimum state of charge.

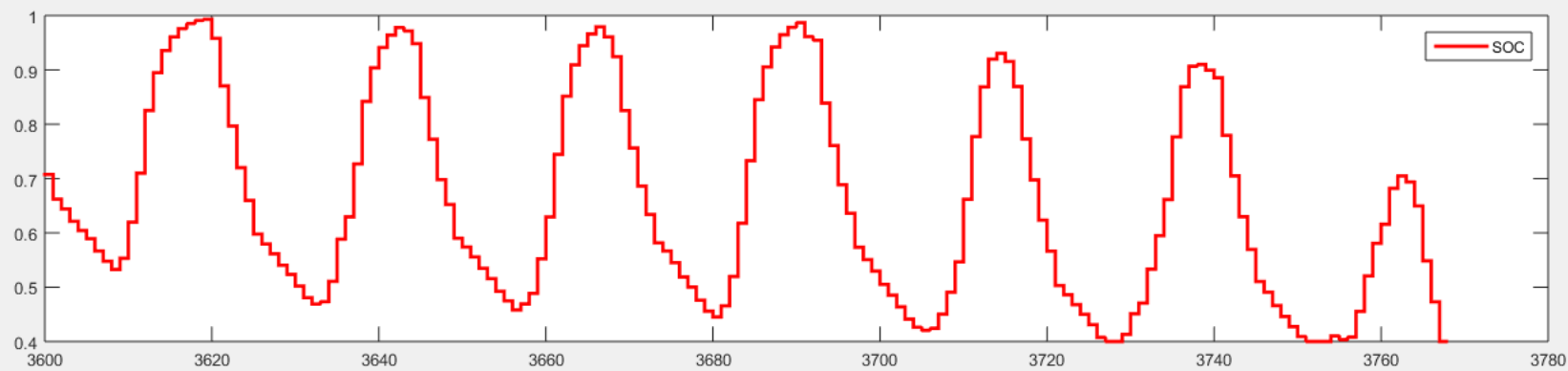
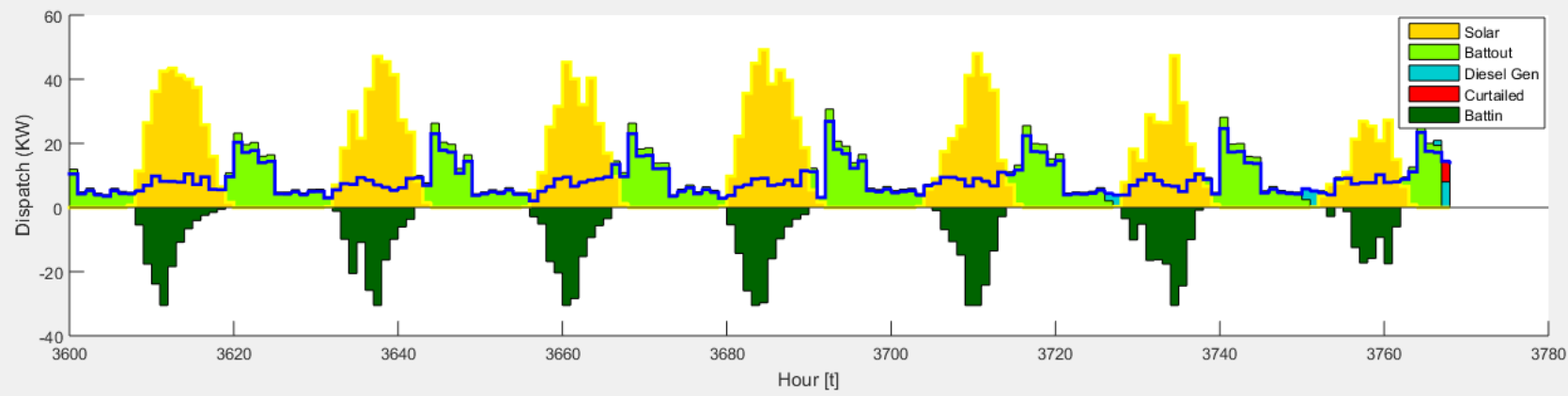

Figure 21. The hourly dispatch for one week and the accompanying change in battery state of charge (SOC)

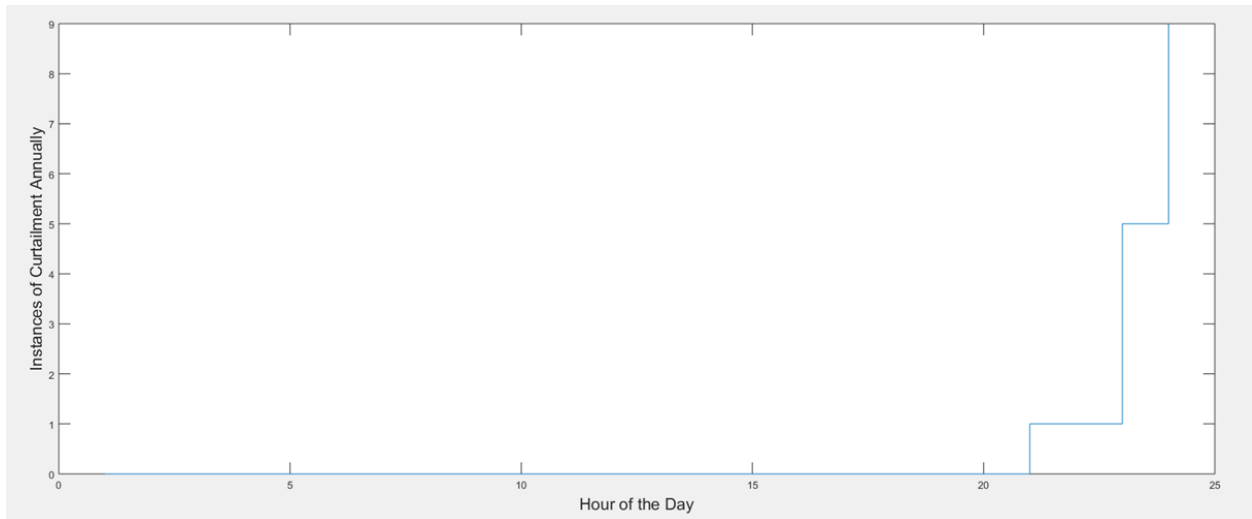

Figure 22. Instances of curtailment per hour of the day (annually)

Figure 22 displays the annual instances of curtailment occurring in each hour of the day. In this case study, the curtailment penalty set to \$2.5 \$/kWh encourages high reliability in the final generation design. Nonetheless, the overall reliability can be broken down into hourly resolution to provide a better intuition of the “usefulness” of the service provided. It is far more critical to have electricity available during the evening hours between 7-9 pm, for instance, than it would be to provide electricity during the daylight hours of 2-3 pm. Instances of curtailment are minimal, but when it does occur, it tends to happen after 9 pm. The frequency of curtailment increases from the hours of 9 pm until 12 am. This time block likely corresponds to the point of the evening at which the battery tends to approach its minimum SOC.

5.4.4 Financial Analysis

In addition to the technical design, LREM outputs the annuity, total investment, running costs, expected revenue, along with performance metrics relating reliability. The technical and economic results from the model are outputted and subjected to final layer of post processing.

In Karambi’s case (as discussed previously), labor and miscellaneous costs are added in the post processing layer. I assume several miscellaneous costs are relevant for the Karambi case based on discussions with Rwandan developers:

1. System installation costs of \$600 a day and average installation being 3 days
2. Engineering Fees of \$1000 for projects 10 kW +
3. Overall operations and maintenance fees of \$20 a month
4. 25 \$ per household for meters
5. 55 \$ per household associated with miscellaneous installation costs

A summary of the financials calculated from these results is shown in Figure 22. Note that this is only one representation; the user is free to work with the raw outputs as he or she wishes. As expected, the differences cost originates from the network design. Placing the generation site at the medical center would increase the investment cost of the network by more than two.

Expected revenue has deliberately been excluded in Table 22. However, a developer may find it worthwhile to benchmark the feasibility of the project against the expected revenue from a potential project. This exercise can be used to assist in tariff setting, or in assessing the financial viability of the scenario under analysis. Many microgrids receive grants for initial capital. Such projects would likely not be concerned with recovering capital and would focus primarily on meeting running and replacement costs.

	Original Site	Medical Center
	Load Following @ diesel = 2	Load Following @ diesel = 2
Upfront Costs		
PV	\$ 33,592.00	\$ 33,592.00
Controller	\$ 11,314.92	\$ 11,314.92
Inverter	\$ -	\$ -
Battery	\$ 69,816.96	\$ 69,816.96
Diesel engine	\$ 2,471.28	\$ 2,471.28
Network	\$ 15,862.00	\$ 39,301.00
Installation	\$ 17,924.00	\$ 17,924.00
Consumer appliances	\$ -	\$ -
Total	\$ 150,981.16	\$ 174,420.16
	\$ -	\$ -
	\$ -	\$ -
Operation cost	USD/year	USD/year
Fuel	\$ 976.78	\$ 976.78
Workmen	\$ 240.00	\$ 240.00
Land rent	\$ -	\$ -
Network O&M	\$ 456.00	\$ 740.00
Equip O&M (gen+net)	\$ 1,424.30	\$ 1,708.30
Battery Replacement	\$ 16,662.53	\$ 16,662.53
Overhead	\$ -	\$ -
Total	\$ 19,759.62	\$ 20,327.62
	\$ -	\$ -
Expected Revenues	USD/year	USD/year
HiLoad Consumers	\$ -	\$ -
LoLoad Consumers	\$ -	\$ -
Total	\$ -	\$ -
	\$ -	\$ -
Total annuity	USD/year	USD/year
Generation site	\$ 30,629.63	\$ 30,629.63
Others	\$ 3,997.30	\$ 7,048.30
Misc	\$ 3,681.69	\$ 3,681.69
Total Revenue	\$ -	\$ -
Total	\$ (34,626.93)	\$ (37,677.93)

Figure 23. The financial summary comparing the two options

5.4.5 Discussion

The results obtained are not unexpected (and are rather obvious), given that the hospital location is quite distanced from the majority of the load. However, LREM’s contribution is nonetheless substantial. Its analytical results 1) **offer quantitative substance to back decisions**, and 2) **provide a sense of the extent of the advantage of one option over the other**. This in itself is quite powerful. Reality is fraught with complexities – one of the most perplexing being unquantifiable social factors. I provide a hypothetical, but illustrative example:

The hospital may be a more secure location for diesel storage, but “security” is difficult to quantify in the model. Given this, the user must make a judgment call. For him/her, the hospital

may be attractive if the increase in investment relative to the centralized field site is only 5%, but not if it exceeds 25%.

The outputs from LREM would certainly be able to assist in such decision making by providing references against which users can use to make well informed cost benefit tradeoffs.

Chapter 6: Scenario Analysis and Sensitivities

6.1 Methods:

The questions posed by this thesis address the overarching question of whether LREM can add value as a practical rural microgrid design tool, and if so, how? Chapters 3-5 discussed LREM's functionalities and described how a developer can apply LREM to inform microgrid design. Quantitative analysis via sensitivity studies can also offer substantial insight on the value of the tool, its strengths, and weaknesses. This chapter examines the variation in behavior, performance, and cost amongst the heuristic strategies when relevant factors are varied. In particular, Chapter 6 seeks to offer insight on the choice of operational strategy and its implications for generation design with LREM. The analysis will be approached from two different angles:

- I. In the first part of the analysis, the effects of the generation design search are withheld. The behavior and performance of each dispatch strategy will be assessed given fixed generation sets, fixed resources, and fixed demand. This section of the analysis seeks to compare the performance of the strategies given specific conditions of resource availability, and aims to determine the conditions under which each operational strategy is best suited.
- II. The second part of the analysis seeks to answer the following questions: How do the operational strategies affect the ultimate generation design? It is conceivable that the logic of the operational strategies may constrain or influence the dispatch and therefore the final design. The least cost generation asset "found" by LREM may vary depending on the operational strategy simulated.

Thus, I approach this question by assessing how the generation design differs when the search is conducted with different operational strategies. Given that the relative price of diesel to battery price will likely be a significant factor in the generation design, I create three pricing scenarios. Under each pricing scenario, each operational strategy will be run while varying the cost of non-served energy (a proxy for reliability) to obtain the generation design. The resulting annuity will be plotted against reliability, and the overall trends from one strategy to the next will be compared against each other. Notable observations in the behavior of in the generation design search, as it interacts with each operational strategy, will be assessed and discussed.

The analysis was conducted with the same generation catalog described in Chapter 5. The hourly load profile is scaled to 40% of the original to expedite the simulations¹⁶.

6.2 Analysis A: Operational Strategies and Fixed Generation Mixes

6.2.1 Overview

Part A assesses the behavior of the strategies under various sets of resources, in isolation of the generation sizing search. Sets of generation assets were pre-defined and held constant. Each operational strategy was simulated given the specified generation mixes.

I expected the availability of solar insolation to be one of the strongest influences on performance amongst the operational strategies. As such, three sizes of PV banks were defined in relation to the

¹⁶ Development on LREM and REM is still ongoing. The results and analysis in this thesis are current as of the state of the model on April 1, 2016.

expected day time load. The intermediate levels best approximate the peak day time demand. Two sizes of storage banks along with six sizes of PV panels created 12 sets of generation assets. I focus the discussion on the cases in which a battery exists, because these are the most interesting. When battery storage is absent, Load Following, Cycle Charging, and Forward Looking Cycle Charging strategies are identical. The ICE was held constant at 6 kW for all sets.

		Storage (kWh)	
		53.82	107.64
PV (kW)	4.92	Set 1	Set 7
	9.84	Set 2	Set 8
	11.5	Set 3	Set 9
	13.1	Set 4	Set 10
	15.6	Set 5	Set 11
	23.8	Set 6	Set 12

All 12 generation sets were run with each operational strategy to obtain the expected total annuity and reliability. The tradeoffs in cost and performance are analyzed to understand how the operational strategies perform under specified resource conditions.

Before proceeding to the results, it is important to note the following items:

- 1) The changes in total annuity arise from the tradeoff between social costs of curtailment, diesel expenditure, and the degradation costs of the battery bank and ICE. This is because the computation of the annuity is calculated with the asset lifetimes (estimated with the energy throughput of the assets). When curtailment is reduced, social costs decrease. However, battery and diesel throughput may also increase, resulting in an increase in investment costs. This should be kept in mind in the comparison of one run to another. In this analysis, CNSE was set to be 5 \$/kWh.
- 2) The relative prices of diesel, storage and non-served energy will affect only the dispatch of the Advanced Battery Valuation strategy. This is because the Cycle Charge, Load Following, and Forward Looking Cycle Charge strategies cannot choose curtail battery charge or discharge, and are obliged to meet demand if it is physically possible. When running LREM with these strategies, the generation sizing decision is affected by costs, but not the dispatch decision¹⁷.

6.2.2 Results

The results are summarized in Figures 24 and 25.

¹⁷ I add this comment for broader explanatory purposes, but please note again that the generation sizing search is irrelevant for Part A of the analysis.

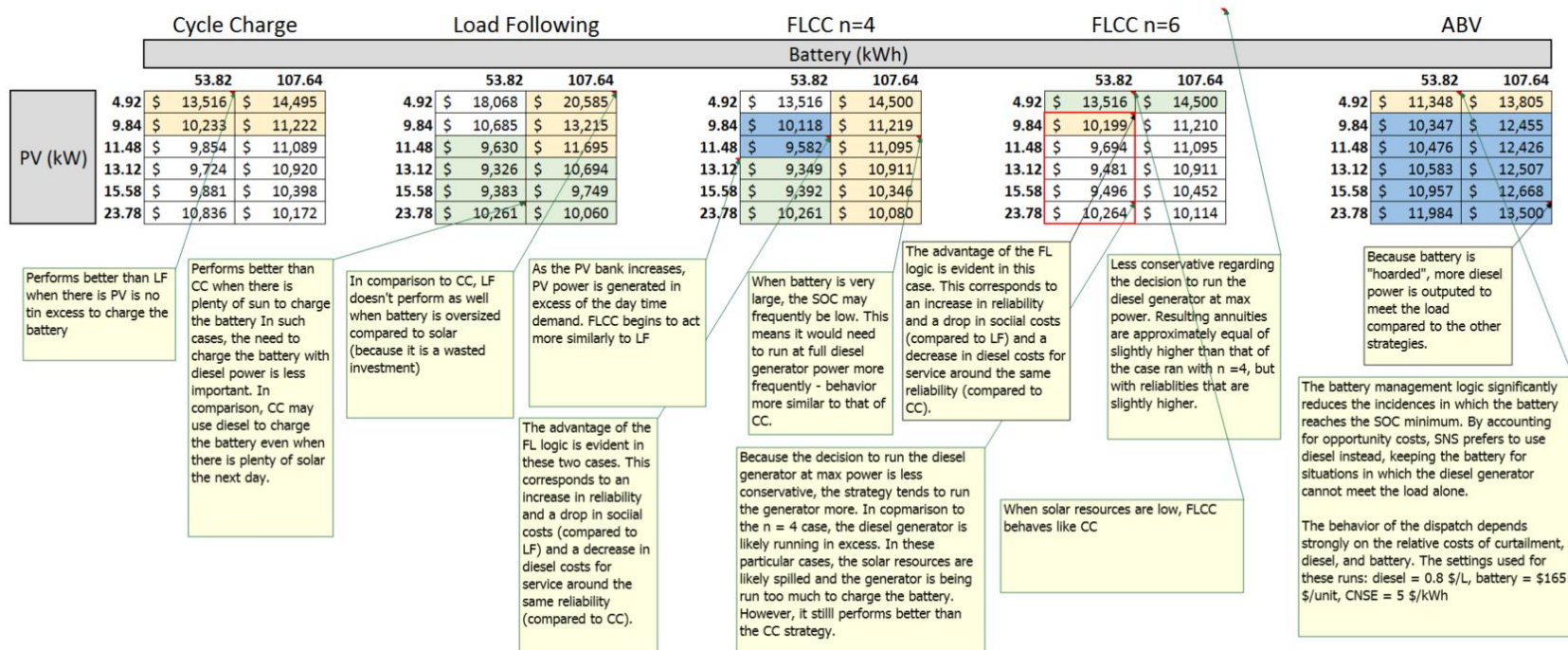

Figure 24. Summary results of the annuities resulting from each generation mix (The strategies are abbreviated in this figure: CC = Cycle Charge, LF = Load Following, FLCC = Forward Looking Cycle Charge, ABV = Advanced Battery Valuation)

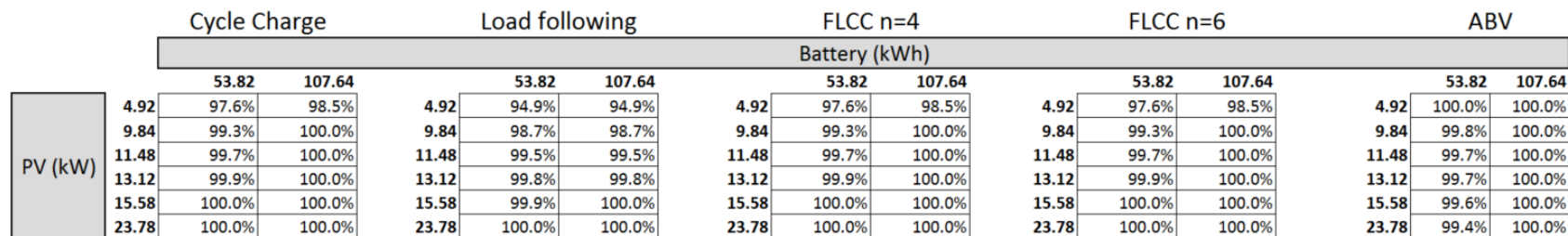

Figure 25. A summary table exhibiting the reliabilities resulting from each generation mix

6.2.3 Discussion

Point 1: Load Following is best suited when plenty of solar power is available.

Under this condition, it is wasteful to use diesel power to charge the battery because solar insolation is in excess. Compared to the Cycle Charge strategy, the Load Following strategy offers similar levels of reliability at a lower cost when plenty of solar insolation is available to charge the batteries.

However, when the battery is oversized relative to the solar resources, the Load Following strategy does not perform as well as the Cycle Charge strategy. This arises because the Load Following strategy minimizes the use of diesel for battery charging. As such, a battery that is oversized with respect to the solar availability is simply a wasted investment.

Point 2: The Cycle Charge strategy successfully hedges against times of low solar insolation.

The Cycle Charging strategy is able to use the ICE to charge the battery, hedging against future situations in which the ICE cannot meet the load. Given this, it performs better than the Load Following strategy (in terms of both total annuity and reliability) when solar resource availability is low.

When intermediate levels of solar insolation are available, Cycle Charge offers higher reliability performance than the Load Following strategy, but at a higher cost. However, the Forward Looking Cycle Charge strategy performs even better than the Cycle Charge strategy. From its runs, we see a decrease in cost while maintaining similar levels of reliability. This is because Forward Looking Cycle Charge only activates the ICE operational constraint when solar is projected to be scarce, reducing both diesel cost and ICE degradation. Cycle Charge is less “intelligent”, and will charge the battery with diesel without regard for projected solar insolation.

Point 3: The Forward Looking Cycle Charge strategy is most advantageous when solar resources are neither extremely abundant, nor scarce.

When PV resources are low, the behavior of the Forward Looking strategy is similar to the Cycle Charge strategy. This is also true when battery resources are increased while solar resources are kept constant¹⁸. When PV resources are high, the Forward Looking Cycle Charge strategy behaves more closely to LF. This occurs because the abundance of solar prevents the ICE operational constraint from coming in effect.

However, the true advantage of the Forward Looking Cycle Charge strategy is seen with solar resources of an intermediate level. Under these conditions, the strategy performs better than the Cycle Charge strategy by limiting wasted diesel. It can also perform better than the Load Following strategy by increasing reliability. The associated change in total annuity can be to be positive or negative, depending on the resulting cost tradeoffs associated with increased generation and lowered social costs.

As described in previous chapters, the variable n describes the number of incidents in which PV is likely to be spilled in the next period of solar availability. The behavior of Forward Looking Cycle Charge strategy can be adjusted by varying the threshold for n . Lowering n causes the strategy to act more conservatively, causing the ICE to be turned on less frequently. For this analysis, the FLCC strategy was run at two

¹⁸ This is because the larger battery will hit lower states of charge more frequently, increasing the need for the ICE to turn on at max power to charge the battery (the ICE operational constraint).

thresholds of 4 and 6, meaning the ICE operational constraint is only effective if the next period of sun sees less than 4 or 6 hourly incidences of solar spillage.

Point 4: The Advanced Battery Valuation strategy manages battery dispatch the best when PV availability is scarce. However, when hoarding the battery does not make practical sense, the battery energy tends to be overvalued.

Load Following, Cycle Charge, and Forward Looking Cycle Charge strategies prioritize battery usage to minimize diesel consumption. Consequently, the battery often hits the minimum SOC and is support of the ICE when it alone is insufficient. The Advanced Battery Valuation strategy, on the other hand, hedges against these occurrences by accounting for the opportunity costs of battery usage. The impact of the Advanced Battery Valuation strategy's logic is that the SOC rarely hits the minimum SOC. When the ICE alone cannot meet demand, the battery is more likely to be able to meet the remainder.

A comparison of the dispatch of the Cycle Charge strategy vs. the Advanced Battery Valuation strategy suggests that the Cycle Charge strategy (Figure 27) would need a larger PV panel or ICE to match the performance of the Advanced Battery Valuation strategy (Figure 26) when simulated over a set of 4.92 kW of PV panels, 50.82 kWh of battery, and 6 kW ICE.

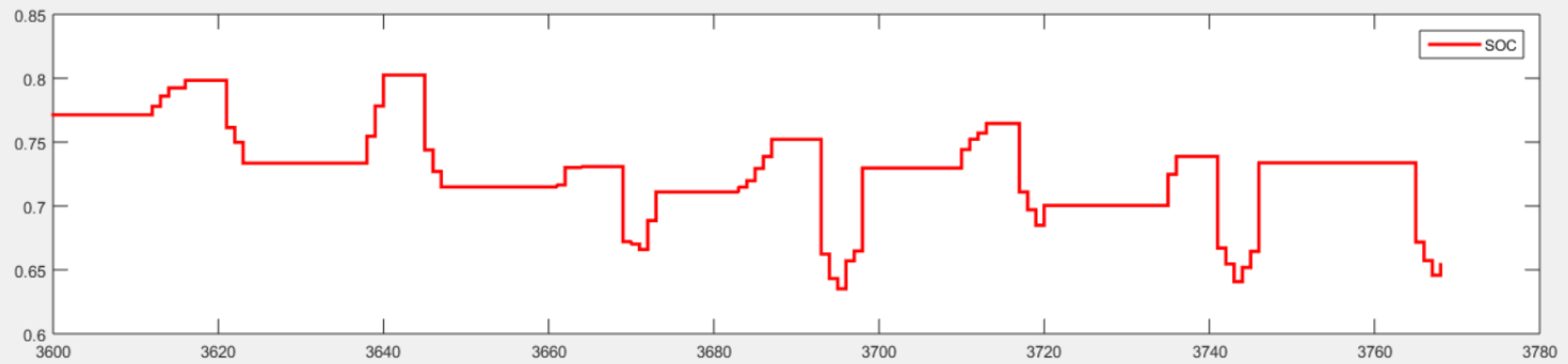
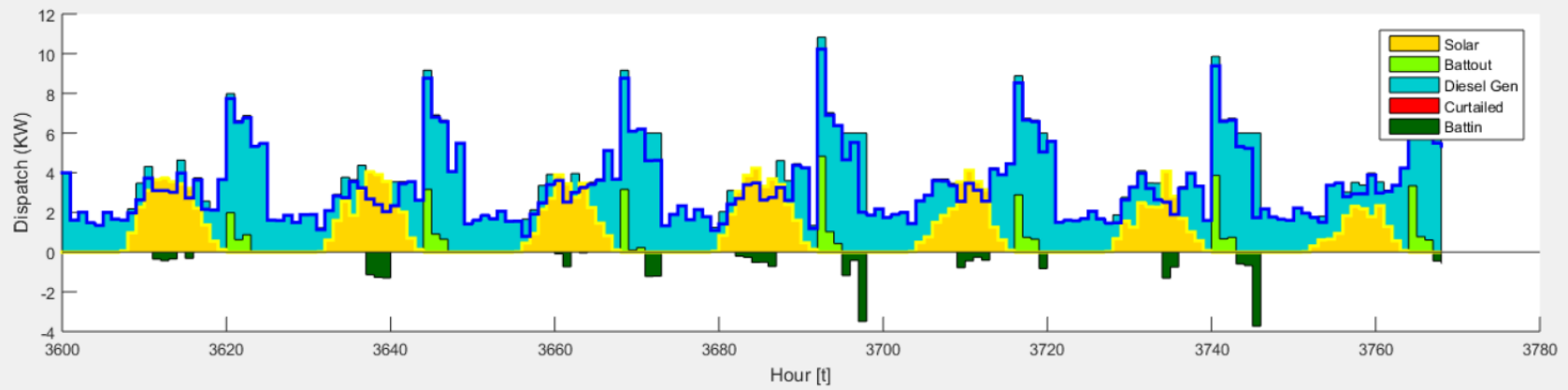

Figure 26. The resulting dispatch from the Advanced Battery Valuation strategy run with: PV = 4.92 KW, battery = 50.82 kWh, ICE = 6 kW

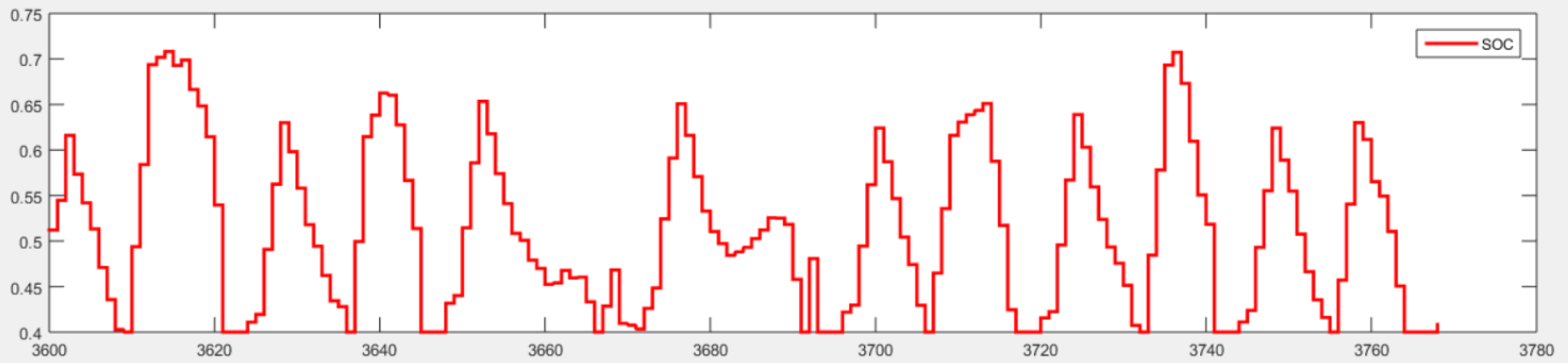
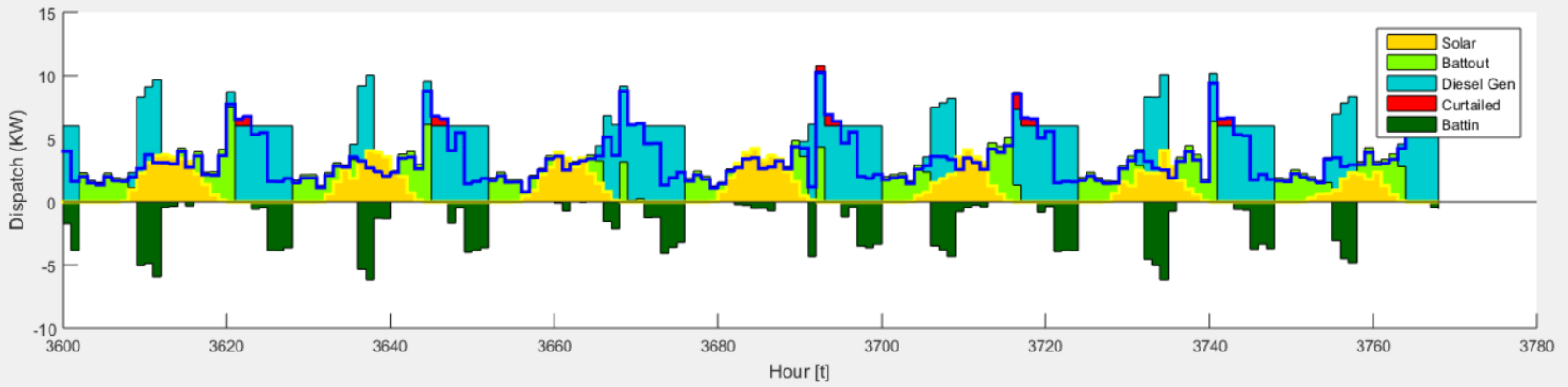

Figure 27. The resulting dispatch from the Cycle Charge strategy run with: PV = 4.92 KW, battery = 50.82 kWh, ICE = 6 kW

It is important to reiterate again that the dispatch of Advanced Battery Valuation is highly dependent on the relative prices of diesel, battery, and non-served energy. Given relatively inexpensive diesel (0.8 \$/L and high CNSE (5 \$/kWh), **when PV availability is limited**, the Advanced Battery Valuation strategy achieves higher reliability overall. However, when solar is not scarce, the battery hoarding behavior is less economical. In such cases, the battery energy is overvalued. The result is that more diesel generation to be dispatched than needed, without the additional benefits of “hoarding” the battery.

6.3 Analysis B: Operational Strategies and the Optimization Search

6.3.1 Overview

Part B of this evaluation seeks to understand how the choice of operational strategy affects the resulting generation design. In this assessment, LREM runs the generation sizing search to identify the optimal generation mix, given the input settings and operational strategy.

Battery and diesel price are the variables that define the three input scenarios. All other inputs are held constant:

	Scenario 1	Scenario 2	Scenario 3
Diesel Price (\$/L)	0.8	0.8	2
Battery Price (\$/unit)	165	213.9	213.9

For each scenario:

- 1) The operational strategy is specified
 - a. The cost of non-served energy (CNSE) is defined.
 - b. The generation design search is run. The objective function in the generation investment search is the total annuity.
 - c. The generation design search identifies the optimal generation mix
 - d. The estimated annuity associated with the resulting design is plotted against the expected reliability. The reliability resulting from the runs are plotted against two forms of the annuity. Real annuity is the annuity arising from true costs incurred, while total annuity is the real annuity in addition to social costs arising from unmet demand.
 - e. The CNSE is incrementally increased, and steps b – d are repeated until all selected CNSE values have been tested. Figure 28 below is an example of plotted results comprised of four runs completed with the Forward Looking Cycle Charge strategy and four different values of CNSE.

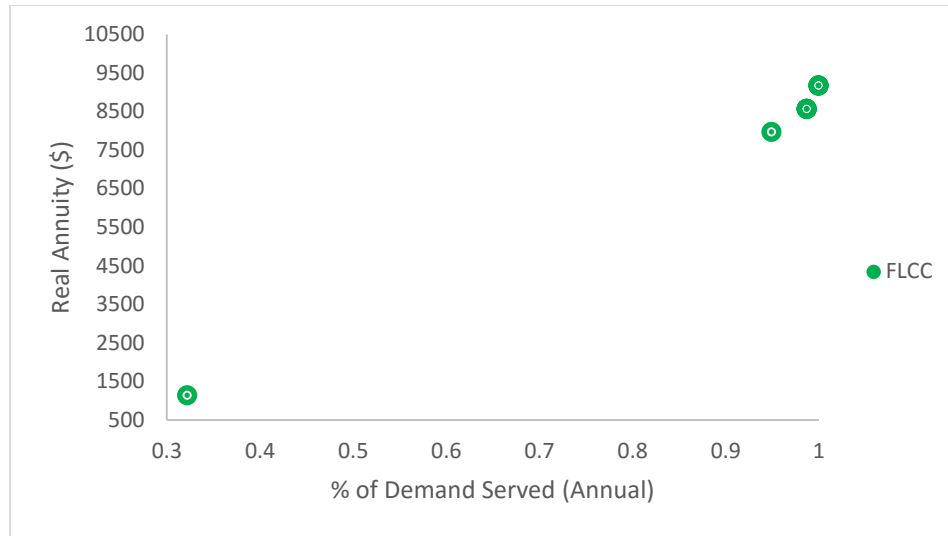

Figure 28. An example of the figure obtained by running the Forward Looking Cycle Charge strategy with varying CNSEs, and plotting against real annuity

- 2) Repeat Step 1 until all operational strategies have been cycled through

Results from the three scenarios are presented in 3 figures:

- 1) The total annuity is plotted against the fraction of demand served for each dispatch strategy. The results from all operational strategies are plotted on the same figure to show trends in annuity vs. reliability across strategies.
- 2) The real annuity is plotted against the fraction of demand served for each dispatch strategy. The results from all operational strategies are plotted on the same figure to show trends in annuity vs. reliability across strategies
- 3) The optimal generation mix associated with each cost of non-served energy is listed in a table for every dispatch strategy

One final note: Unlike the others, the Simplest DC strategy assumes a DC load. To serve an AC load, an inverter would need to be modeled, and the final mix of generation assets would likely increase due to the incurred inverter losses. The results associated with the Simplest DC strategy therefore cannot be directly compared against the results from the others.

6.3.2 Results

Scenario 1: diesel cost = 0.8 \$/L, batteries = 165 \$/unit

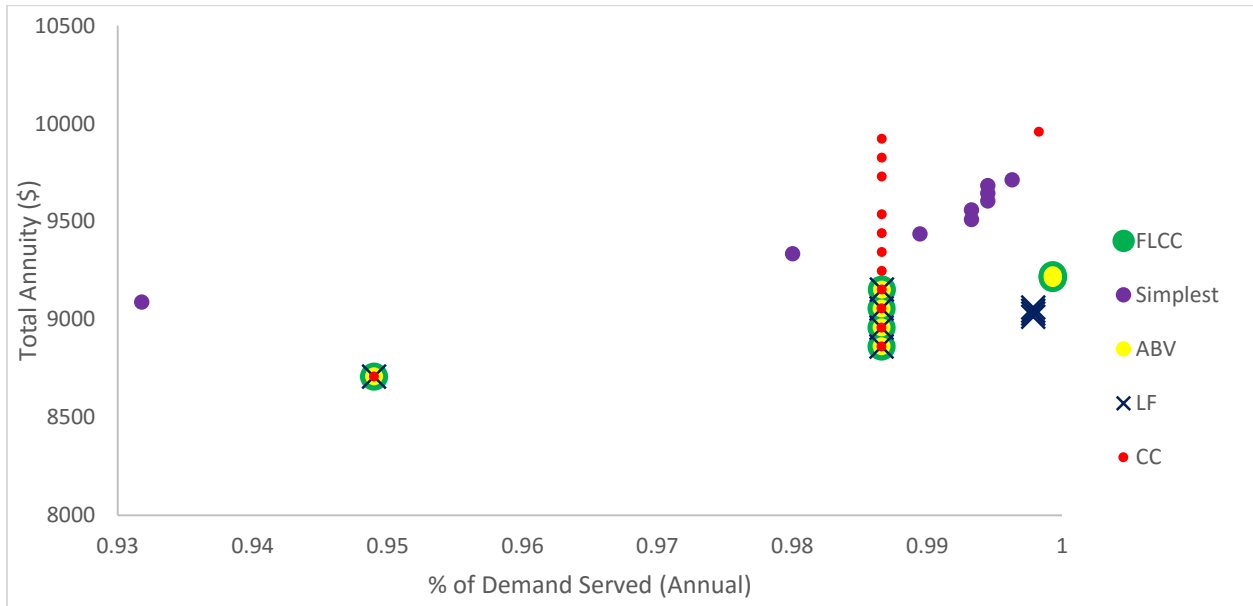

Figure 29. Results from Scenario 1 (diesel = 0.8 \$/L, batteries = 165 \$/unit): Total annuity vs. percentage of annual demand served

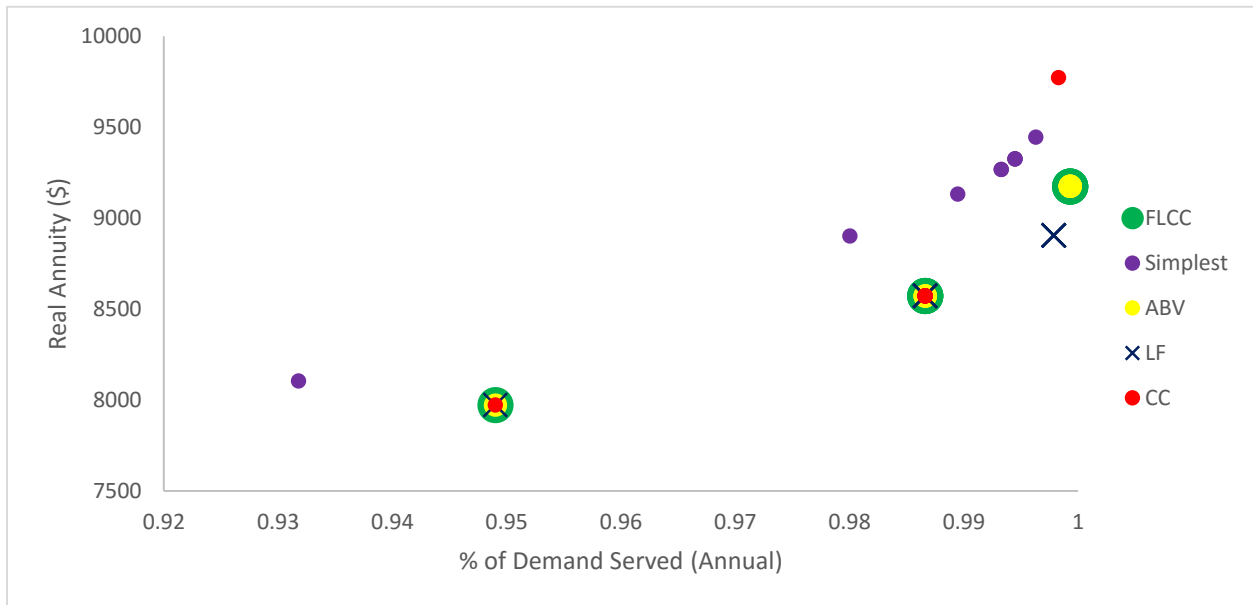

Figure 30. Results from Scenario 1 (diesel = 0.8 \$/L, batteries = 165 \$/unit): Real annuity vs. percentage of annual demand served

Table 12. Results from Scenario 1 (diesel = 0.8 \$/L, batteries = 165 \$/unit): Generation design

CNSE	CC			FLCC			LF			Simplest DC			ABV		
	Solar	Storage	Genset	Solar	Storage	Genset	Solar	Storage	Genset	Solar	Storage	Genset	Solar	Storage	Genset
0.25	7.38	0	0	7.38	0	0	7.38	0	0	6.56	0	0	7.38	0	0
0.5	9.84	0	6	9.84	0	6	9.84	0	6	18.04	91.08	0	9.84	0	6
0.75	9.84	0	8	9.84	0	8	9.84	0	8	20.5	99.36	0	9.84	0	8
1	9.84	0	8	9.84	0	8	9.84	0	8	21.32	103.5	0	9.84	0	8
1.25	9.84	0	8	9.84	0	8	9.84	0	8	22.14	103.5	0	9.84	0	8
1.5	11.48	0	8	11.48	0	8	11.48	0	8	22.14	103.5	0	11.48	0	8
1.75	11.48	0	8	11.48	0	10	9.84	20.7	8	22.14	107.64	0	11.48	0	10
2	11.48	0	8	11.48	0	10	9.84	20.7	8	22.14	107.64	0	11.48	0	10
2.25	11.48	0	8	11.48	0	10	9.84	20.7	8	22.14	107.64	0	11.48	0	10
2.5	11.48	0	8	11.48	0	10	9.84	20.7	8	22.96	107.64	0	11.48	0	10
3	11.48	0	8												
3.25	11.48	0	8												
3.5	11.48	0	8												
3.75	12.3	53.82	6												
4	12.3	53.82	6												

Scenario 2: Diesel cost = 0.8 \$/L, batteries = 213.9 \$/unit

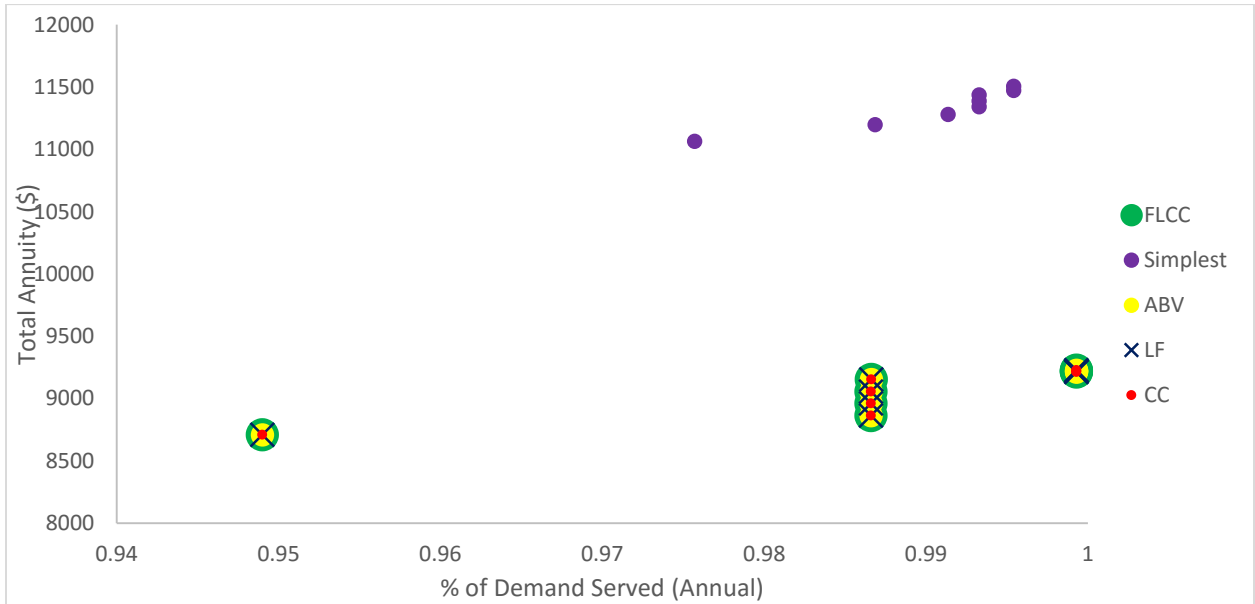

Figure 31. Results from Scenario 2 (diesel = 0.8 \$/L, batteries = 213.9 \$/unit): Total annuity vs. percentage of annual demand served

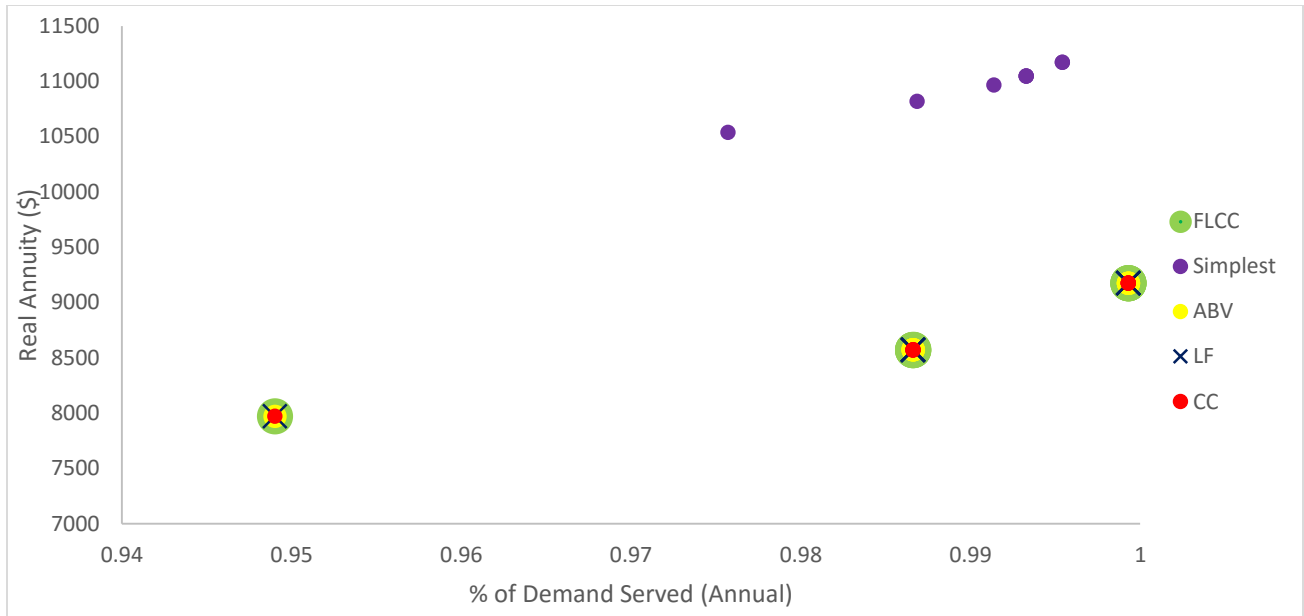

Figure 32. Results from Scenario 2 (diesel = 0.8 \$/L, batteries = 213.9 \$/unit): Real annuity vs. percentage of annual demand served

Table 13. Results from Scenario 2 (diesel = 0.8 \$/L, batteries = 213.9 \$/unit): Generation Design

CNSE	CC			FLCC			LF			Simplest DC			ABV		
	Solar	Storage	Genset	Solar	Storage	Genset	Solar	Storage	Genset	Solar	Storage	Genset	Solar	Storage	Genset
0.25	7.38	0	0	7.38	0	0	7.38	0	0	6.56	0	0	7.38	0	0
0.5	9.84	0	6	9.84	0	6	9.84	0	6	9.84	0	0	9.84	0	6
0.75	9.84	0	8	9.84	0	8	9.84	0	8	20.5	95.22	0	9.84	0	8
1	9.84	0	8	9.84	0	8	9.84	0	8	21.32	99.36	0	9.84	0	8
1.25	9.84	0	8	9.84	0	8	9.84	0	8	22.14	99.36	0	9.84	0	8
1.5	11.48	0	8	11.48	0	8	11.48	0	8	22.14	103.5	0	11.48	0	8
1.75	11.48	0	10	11.48	0	10	11.48	0	10	22.14	103.5	0	11.48	0	10
2	11.48	0	10	11.48	0	10	11.48	0	10	22.14	103.5	0	11.48	0	10
2.25	11.48	0	10	11.48	0	10	11.48	0	10	22.96	103.5	0	11.48	0	10
2.5	11.48	0	10	11.48	0	10	11.48	0	10	22.96	103.5	0	11.48	0	10

Scenario 3: Diesel cost = 2 \$/L, batteries = 213.9 \$/unit

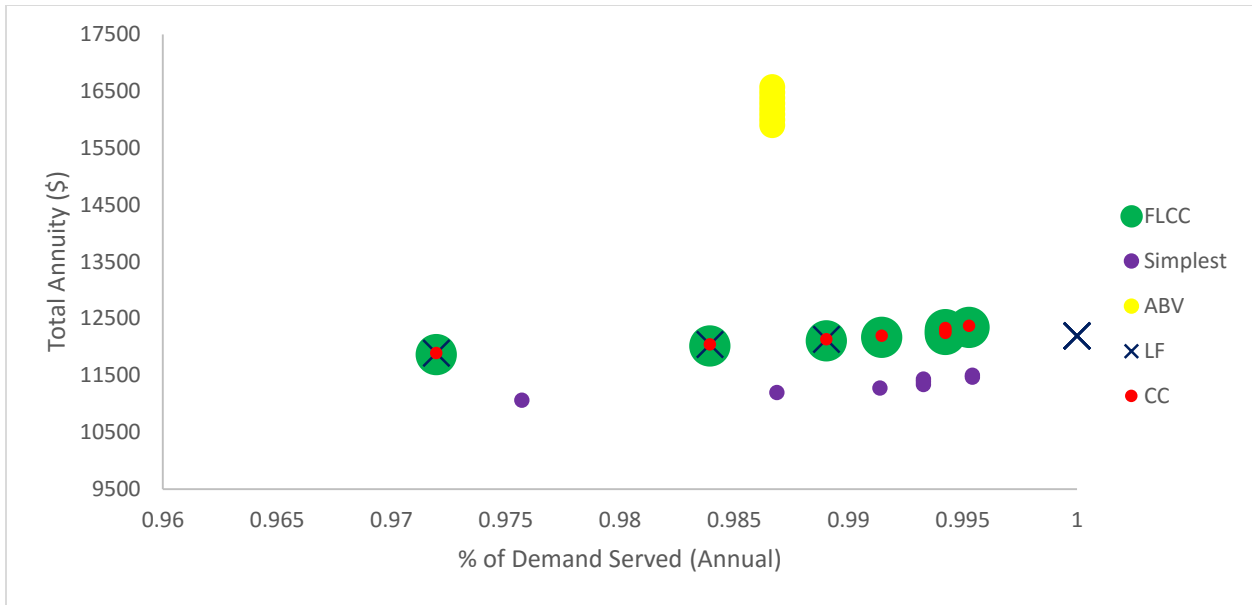

Figure 33. Results from Scenario 3 (diesel = 2 \$/L, batteries = 213.9 \$/unit): Total annuity vs. percentage of annual demand served

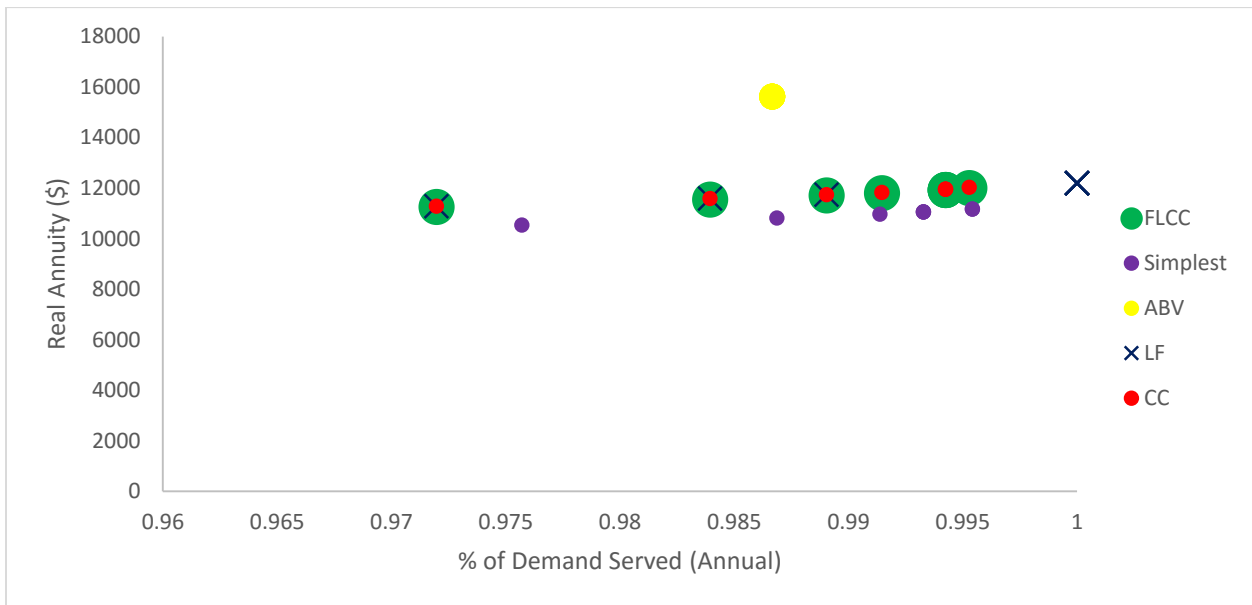

Figure 34. Results from Scenario 3 (diesel = 2 \$/L, batteries = 213.9 \$/unit): Real annuity vs. percentage of annual demand served

Table 14. Results from Scenario 3 (diesel = 2 \$/L, batteries = 213.9 \$/unit): Generation designs

CNSE	CC			FLCC			LF			Simplest DC			ABV		
	Solar	Storage	Genset	Solar	Storage	Genset	Solar	Storage	Genset	Solar	Storage	Genset	Solar	Storage	Genset
0.25	7.38	0	0	7.38	0	0	7.38	0	0	6.56	0	0	7.38	0	0
0.5	9.84	0	0	9.84	24.84	0	9.84	24.84	0	9.84	0	0	9.84	0	0
0.75	21.32	99.36	0	21.32	99.36	0	21.32	99.36	0	20.5	95.22	0	14.76	0	8
1	22.14	103.5	0	22.14	103.5	0	22.14	103.5	0	21.32	99.36	0	14.76	0	8
1.25	22.96	103.5	0	22.96	103.5	0	22.96	103.5	0	22.14	99.36	0	14.76	0	8
1.5	22.96	107.64	0	22.96	107.64	0	22.14	103.5	6	22.14	103.5	0	14.76	0	8
1.75	23.78	107.64	0	23.78	107.64	0	22.14	103.5	6	22.14	103.5	0	14.76	0	8
2	23.78	107.64	0	23.78	107.64	0	22.14	103.5	6	22.14	103.5	0	14.76	0	8
2.25	23.78	107.64	0	23.78	107.64	0	22.14	103.5	6	22.96	103.5	0	14.76	0	8
2.5	23.78	111.78	0	23.78	111.78	0	22.14	103.5	6	22.96	103.5	0	14.76	0	8

6.3.3 Discussion

Point 1: When optimizing the generation design, it is important to use the operational strategy that reflects the expected operations of the microgrid.

The results suggest that the optimal generation design can indeed be influenced by the behavior of the operational strategies. The tables of results show significant differences in optimal solution mixes and sets across the operational strategies. We see that the optimal generation design obtained when operating under one strategy is not necessary the optimal for the others.

Figure 35 illustrates dispatch with the optimal generation mix obtained by running Cycle Charge strategy. Figure 36 illustrates the dispatch with the optimal generation mix obtained by the Load Following strategy. The optimal mix obtained by the Load Following strategy results in a lower total annuity than the optimal mix obtained by the Cycle Charge strategy.

When Cycle Charge is forced to run with the optimal generation mix obtained with the Load Following strategy, the annuity obtained is: 1) greater than that obtained with its own optimal mix, and 2) greater than that obtained by the Load Following strategy. Figure 37 exhibits sample hours of the dispatch.

	Cycle Charge (Optimal Set)	Cycle Charging (run with Optimal Mix Obtained by Load Following)	Load Following (Optimal Set)
CNSE (\$/L)	2	2	2
ICE (kW)	8	8	8
Storage (kWh)	0	20.7	20.7
PV bank (kW)	11.48	9.84	9.84
Total Annuity (\$)	9,151	10,553	9,029

The ICE operational constraint of Cycle Charge strategy and Forward Looking Cycle Charge strategy makes it to be more difficult to add assets on incrementally. An illustrative example conveys this well.

The behavior of the Cycle Charge strategy changes significantly when a battery is included into the mix. In Figure 37, the Cycle Charge logic forces the ICE to turn on at max power when the SOC of the battery drops below 60% (the specified threshold). This happens frequently for smaller batteries, and thus, the diesel must excessively charge the battery with diesel power. The Load Following strategy does not exhibit undesirable behavior upon incremental addition of battery storage (as seen in Figure 36).

The operational constraint on the ICE is helpful in promoting reliability in systems with insufficient or unreliable solar insolation. However, a consequence is that this strategy tends to disfavor adding smaller increments of storage to diesel systems. This is not to say that the strategy will never favor a diesel/storage/PV mix. Simply, the mixture will likely only occur at high storage capacities.

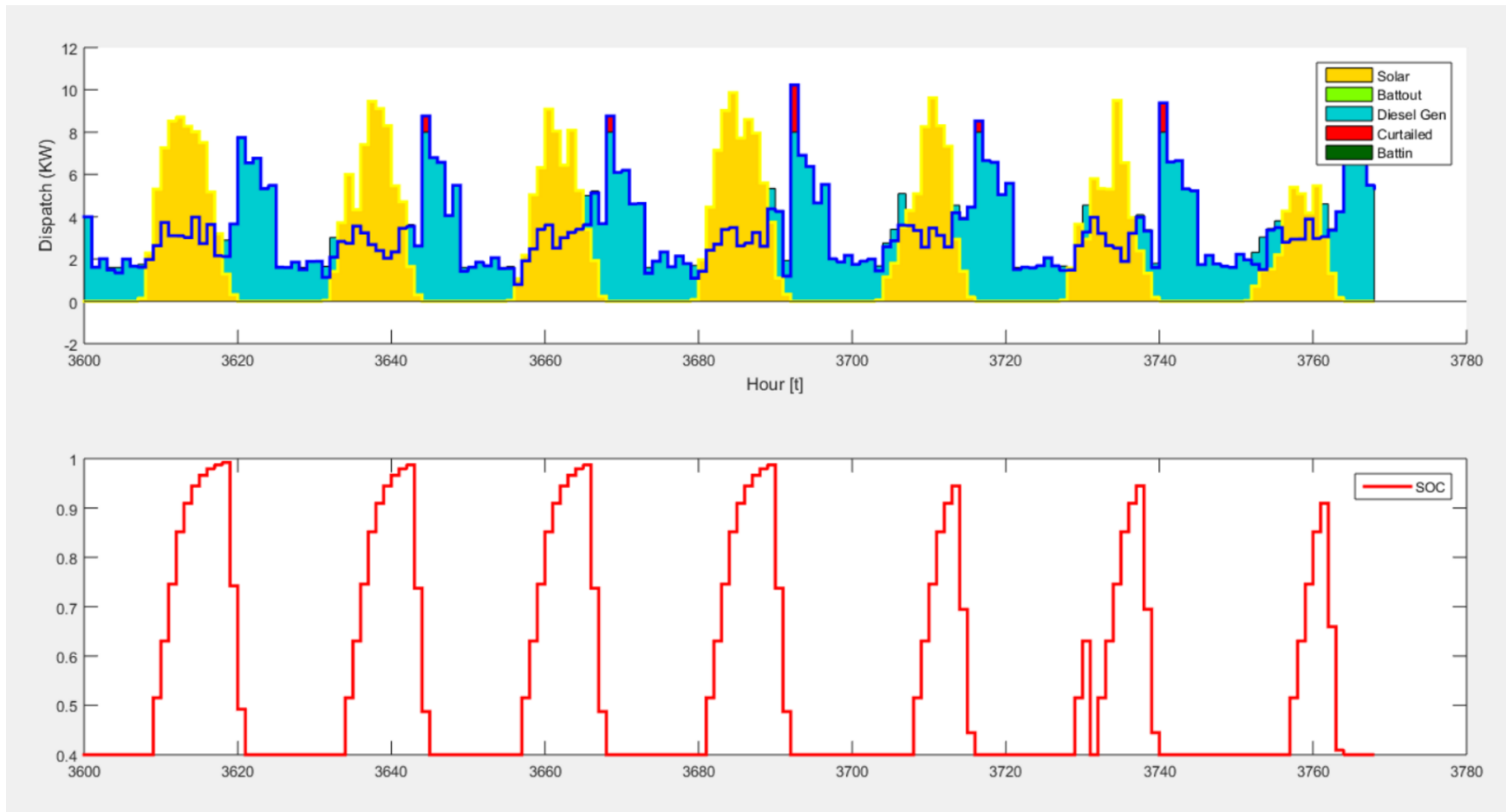

Figure 35. Dispatch of the optimal generation design (PV = 11.48 kW, battery = 0, ICE = 8 kW) obtained by running the Cycle Charge strategy (settings: CNSE = 2 \$/kWh, battery = \$165 \$/unit, diesel = 0.8 \$/L). The resulting total annuity = \$9344.

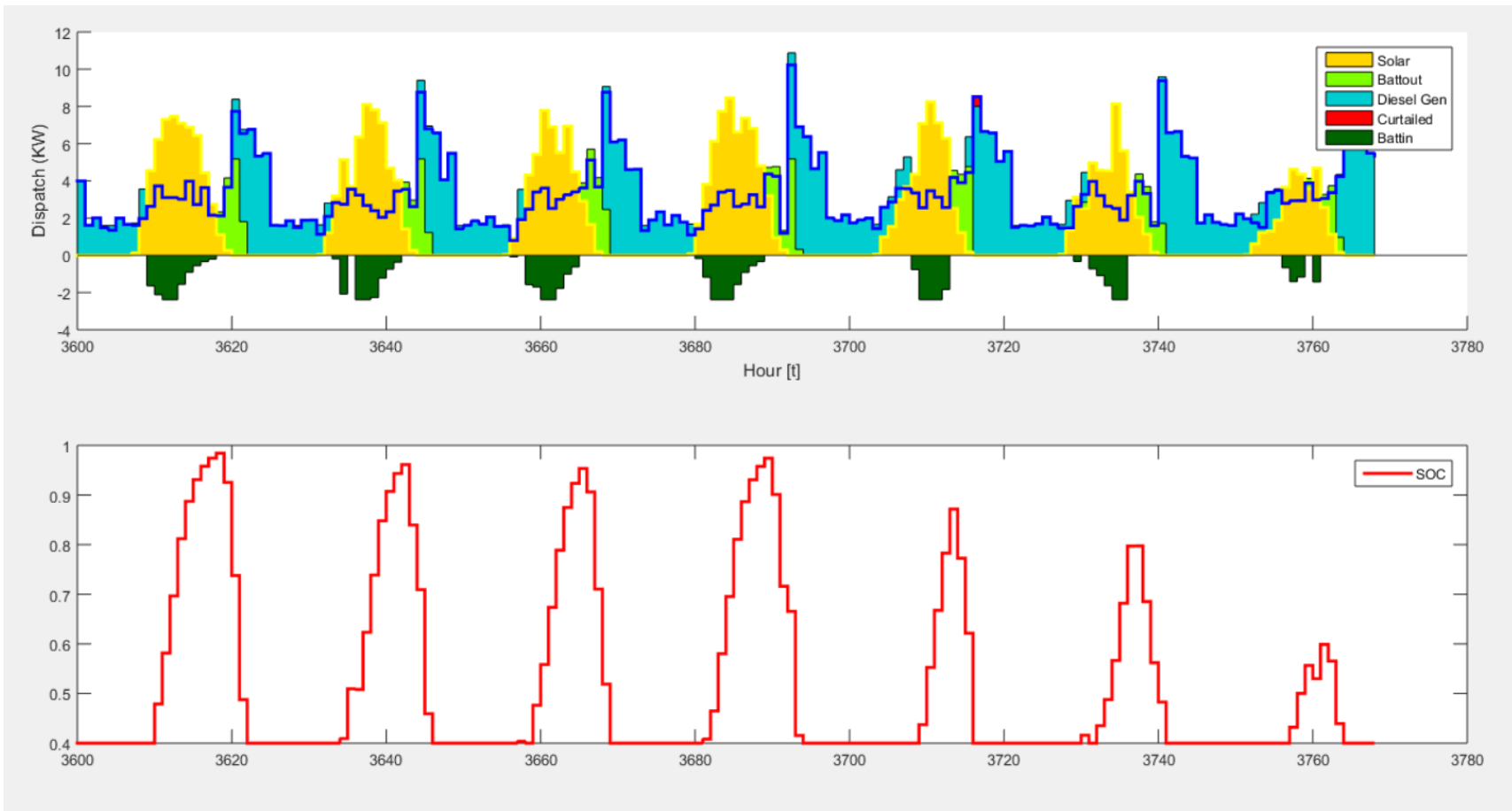

Figure 36. Dispatch of the optimal generation design (PV = 9.84 kW, battery = 20.7 kWh, ICE = 8 kW) obtained by running the Load Following strategy (settings: CNSE = 2 \$/kWh, battery = \$165 \$/unit, diesel = 0.8 \$/L). The resulting total annuity = \$9029.

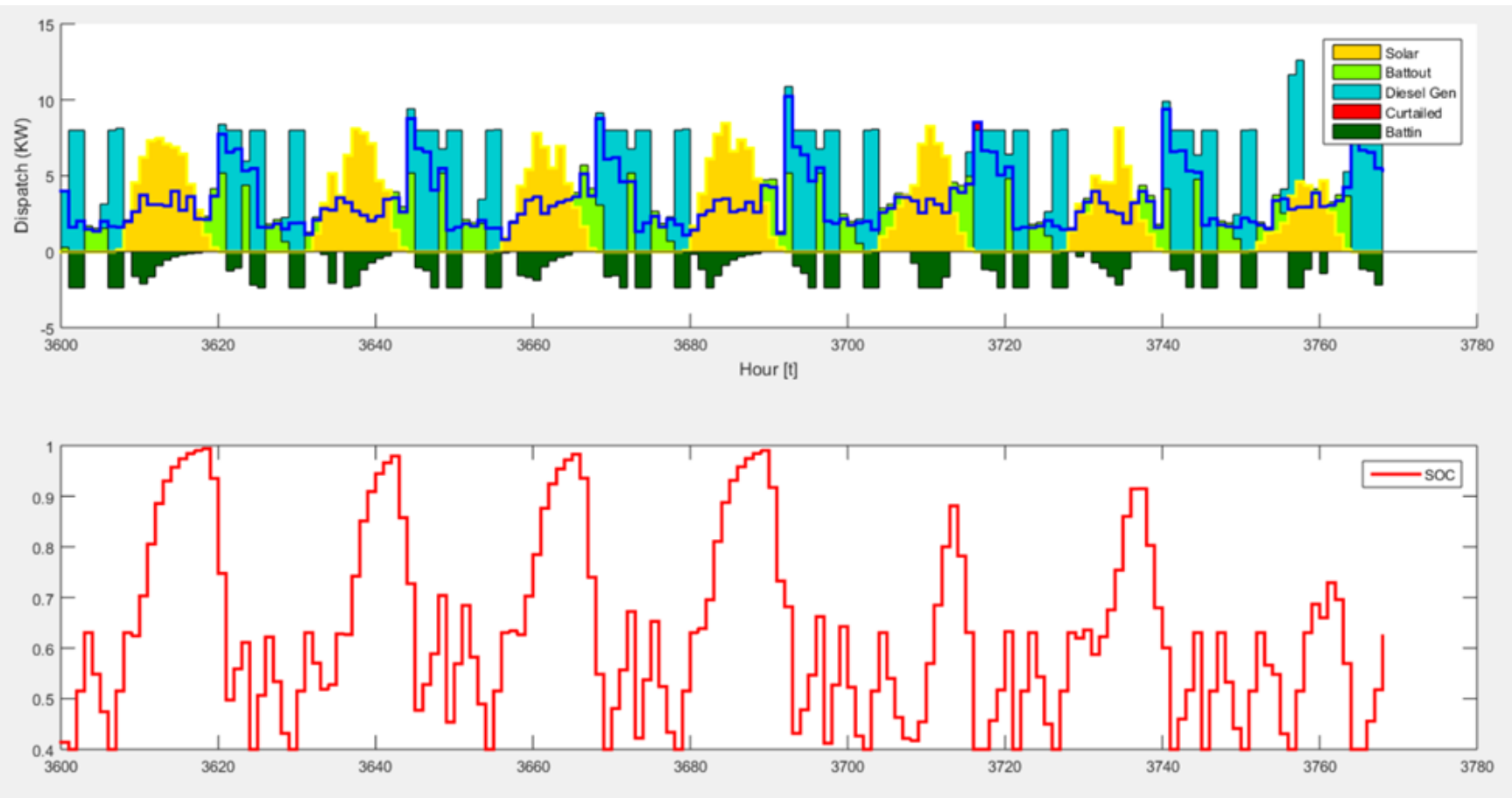

Figure 37. Dispatch when the Cycle Charge strategy is run with the optimal generation design ($PV = 9.84$ kW, battery = 20.7 kWh, ICE = 8 kW) obtained by running the Load Following strategy (settings: CNSE = 2 \$/kWh, battery = \$165 \$/unit, diesel = 0.8 \$/L). The resulting total annuity = \$10,553.

In Scenario 3, the Advanced Battery Valuation strategy was the only one in which the optimal solution did not include battery storage. This strategy tends to result in resource oversizing due to its battery hoarding behavior. Battery throughput is minimized because of two reasons: 1) to account for battery degradation in the dispatch decision, and 2) to account for opportunity costs by actively choosing to curtail battery charging and discharging. Put in another way, the battery is deliberately not discharged or charged to its full potential.

These effects are particularly important at low CNSE and when diesel and/or battery resources are expensive. This is because the decision to charge the battery is determined based on a ranking of asset costs. The battery charging will be curtailed depending on the costs of generation resources needed to charge the battery (including battery degradation) in relation to the battery value.

Battery dispatch is also affected. At lower SOCs, the battery value is higher, thus, the battery is less likely to be discharged. This effect is less pronounced at higher CNSE. When CNSE is increased, the system is less likely to curtail discharge because the cost of discharging relative to curtailment is less. The case example below provides an insightful illustration. These runs were conducted with the Advanced Battery Valuation operating strategy with diesel set to \$2/L and battery at a unit cost of \$213.9/ unit.

When CNSE was set to 1.5 \$/kWh, the resulting solution exhibits frequent solar curtailment, and produced the following optimal generation mix:

Diesel = 0 kW
Solar =14.5 kW
Storage = 107.64 kWh
Annuity = \$9,394

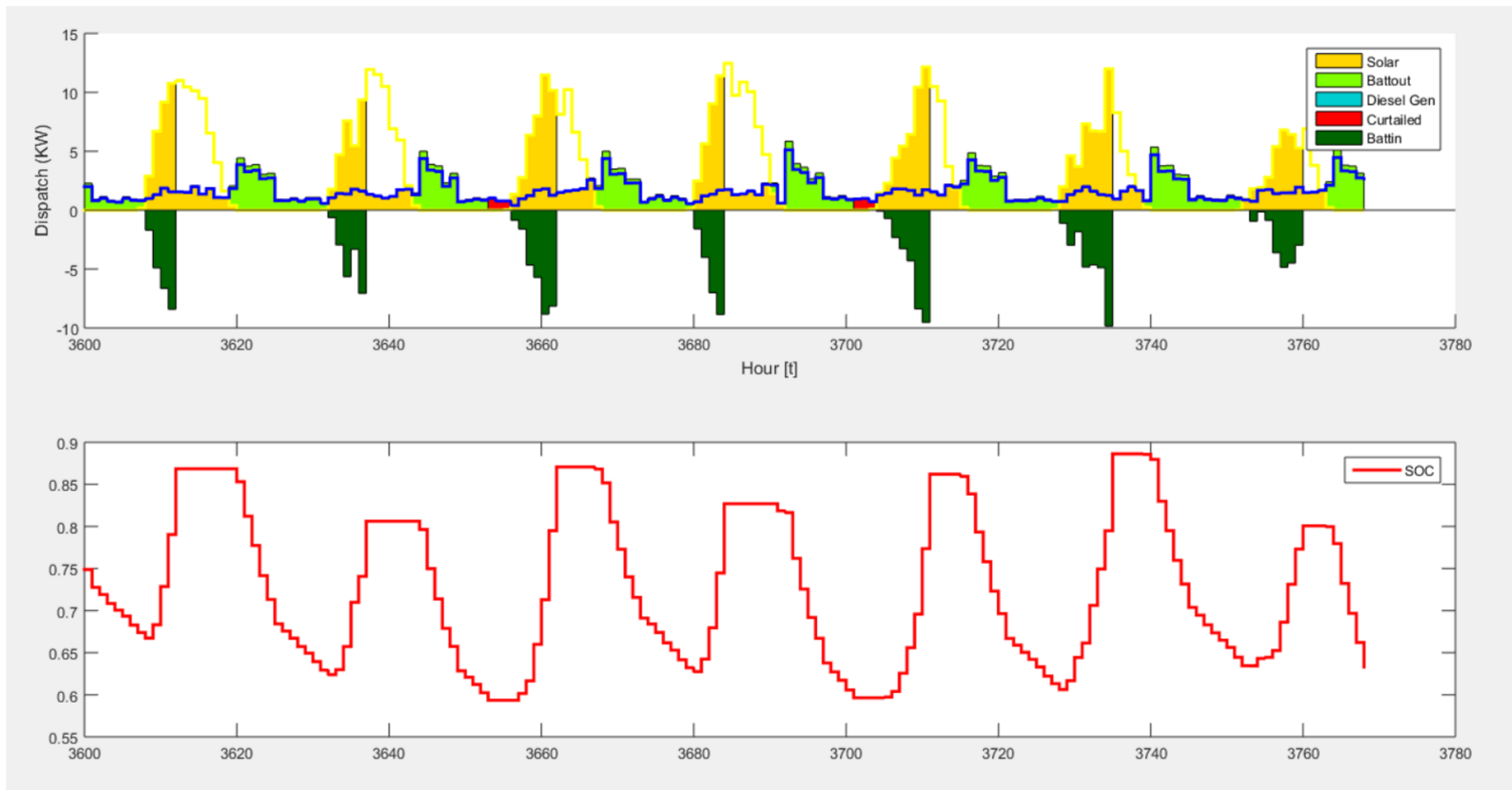

Figure 38. Dispatch of the optimal generation design (PV = 14.5 kW, battery =107.64 kWh, ICE = 0 kW) obtained by running the Forward Looking Cycle Charge strategy (settings: CNSE = 1.5 \$/kWh). The resulting total annuity = \$9394.

When the CNSE was set to 1.75 \$/kWh, the optimal solution was a smaller set of PV and storage, but nonetheless produced a higher reliability:

Diesel = 0 kW
Solar = 11.5 W
Storage = 71.76 kWh
Annuity = \$6462

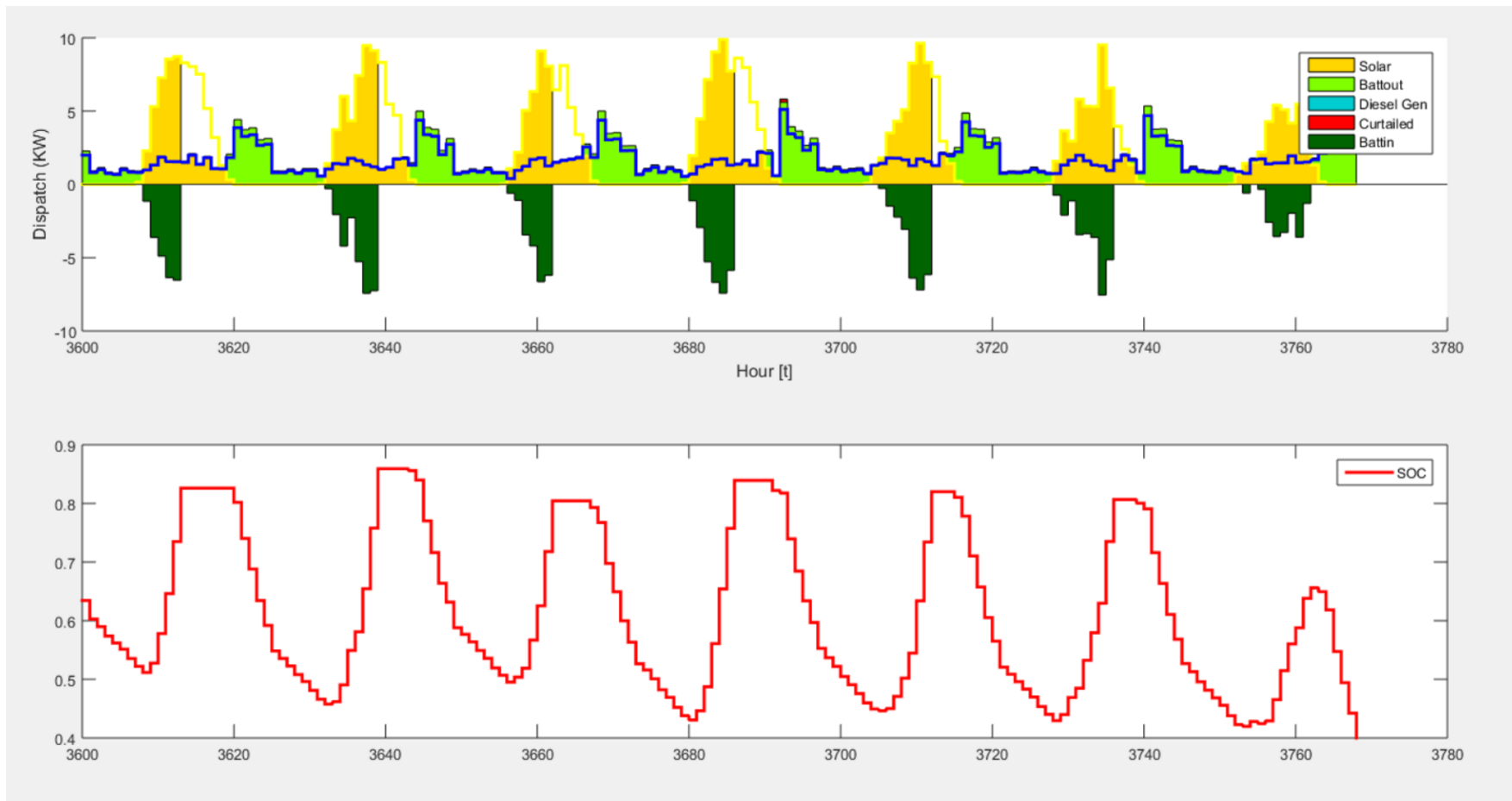

Figure 39. Dispatch of the optimal generation design (PV = 11.5 kW, battery =71.76 kWh, ICE = 0 kW) obtained by running the Forward Looking Cycle Charge strategy (settings: CNSE = 1.75 \$/kWh). The resulting total annuity = \$6462.

Given that a smaller set of generation assets was able to perform at higher reliability when CNSE was slightly increased, it would seem that the optimal generation set for the former case should also be smaller. However, when the same smaller set of generation assets is run with the Advanced Battery Valuation strategy at a CNSE of 1.5, we see that the solution is indeed non-optimal:

Diesel = 0 kW
Solar = 11.5 kW
Storage = 71.76 kWh
Annuity = \$10155

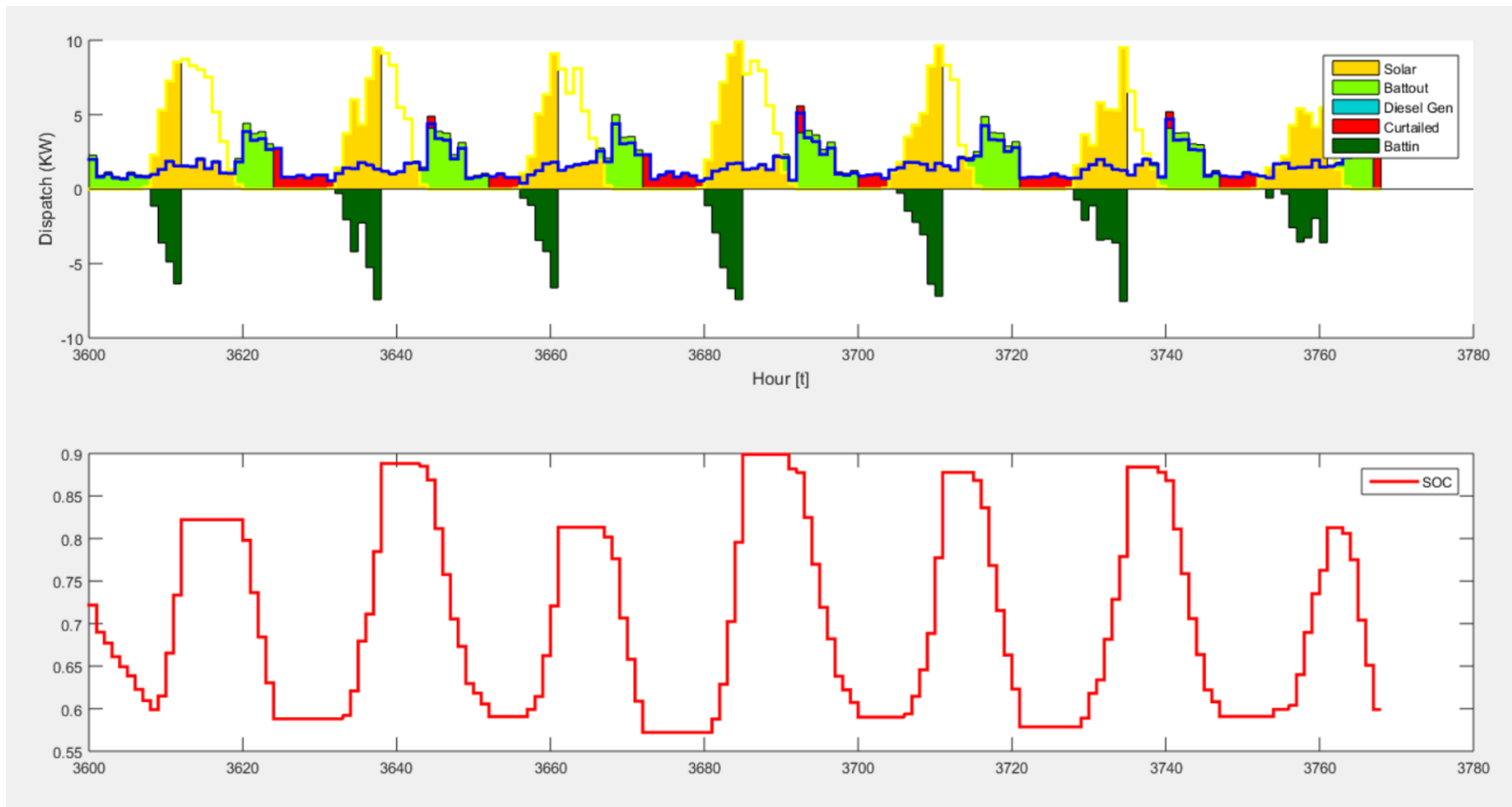

Figure 40. Dispatch when the Forward Looking Cycle Charge strategy is run with the optimal generation design (PV = 11.5 kW, battery = 71.76 kWh, ICE = 0 kW) obtained by running the same strategy at a higher CNSE (settings: CNSE = 1.5 \$/kWh). The resulting total annuity = \$10,155.

Figures 38 and 40 were run with a lower CNSE, and accordingly, show more instances of battery charging curtailment (the blank white space between the yellow and red lines) than Figure 39. When battery charging curtailments are frequent (as in this case), a larger system can capture and store more energy during periods when battery charging is allowed. This causes larger systems to be more economical than smaller systems at lower CNSE's.

Point 2: The relative costs of the battery and the diesel generation can influence the optimal generation design.

The results show that in scenarios in which diesel = 0.80 \$/L, solutions tend to be more favorable towards diesel usage. When diesel is set to 2 \$/L, storage tends to be favored.

Table 15 and 16 presents the influence of diesel costs on the generation set when battery costs are held constant (obtained with the Cycle Charge and Load Following strategies). CNSE was held constant at 2.5 \$/kWh while the cost of diesel was varied. When diesel is inexpensive, the solutions favor diesel generation. As diesel price increases, the solutions begin incorporating more storage¹⁹.

Table 15. Results from the Cycle Charge strategy run with varying diesel prices

Total cost annuity	Penalty (CNSE) Hi	Diesel Price	SolarCapacity	Storage Capacity	Genset Capacity	Total Cost annuity (real - not including CNSE)
\$ 5,649	2.5	0.25	9.02	0	10	\$ 5,598
\$ 7,294	2.5	0.5	9.84	0	10	\$ 7,243
\$ 9,233	2.5	0.75	9.84	0	8	\$ 8,268
\$ 10,369	2.5	1	22.14	111.78	6	\$ 10,369
\$ 10,432	2.5	1.25	22.14	111.78	6	\$ 10,432
\$ 10,485	2.5	1.5	23.78	111.78	0	\$ 10,145
\$ 10,485	2.5	1.75	23.78	111.78	0	\$ 10,145
\$ 10,485	2.5	2	23.78	111.78	0	\$ 10,145
\$ 10,485	2.5	2.25	23.78	111.78	0	\$ 10,145

¹⁹ In relation to the discussion in Point 1 of Part B, the patterns in Tables 8 and 9 also show how configurations with sets with ICEs and small battery capacities tend to be disfavored. This is seen in the trends of optimal generation design. The generation design results obtained with the Cycle Charge strategy avoids small battery capacities. This is not seen in the results obtained with the Load Following strategy.

Table 16. Results from the Load Following strategy run with varying diesel prices

Total cost annuity	Penalty (CNSE) Hi	Diesel Price	SolarCapacity	Storage Capacity	Genset Capacity	Total Cost annuity (real - not including CNSE)
\$ 11,653	2	1.25	11.48	20.7	8	\$ 11,611
\$ 12,078	2	1.5	21.32	103.5	6	\$ 12,078
\$ 12,145	2	1.75	22.14	103.5	6	\$ 12,145
\$ 12,195	2	2	22.14	103.5	6	\$ 12,195

Point 3: Increases in reliability often occur in large steps due to the discrete nature of the generation assets.

The reliability tends to increase in distinct jumps as generation increases due to rising cost of non-served energy. The trend is clearer in the Figures showing real annuity vs. reliability. I refer back to Figure 28 which shows the large jump in reliability. A particularly large increase in reliability is seen when storage and diesel are added in all three scenarios. Though not shown, the data collected for each operational strategy showed the same pattern. In all cases, a substantial increase in reliability from approximately 30% to 90% is seen when the system when ICE or battery storage is added to the mix.

The discrete nature of the assets is particularly consequential for scenarios with very low demand. ICES with automatic switches may not be available in small sizes (the smallest seen by contacts in India were around 6 kW). Thus, systems serving lower demand may be forced to rely on PV and battery mixes.

Point 4: As expected, the real annuity increases as reliability increases.

The social costs of curtailment tend to convolute the visual analysis of the results (as seen by the unusual “staircase” patterns). It was discussed previously that the CNSE is used as a proxy for reliability. When it is increased to increase reliability, the total social costs will increase even if the amount of load served remains the same. The system tends to choose to stay with the same set of generation assets even as the CNSE increases, until the CNSE hits a certain point. At this “threshold”, the system decides to increase generation. The result is a tradeoff in costs of increasing generation and decreasing social costs (more load is now served, meaning less social costs from curtailment). In contrast, the real annuity simply makes large jumps as CNSE is increased and capital and operational costs increase to meet more demand. It is not convoluted by the social costs.

Point 5: The danger of falling into a local minimum is a potential hazard, and minimizing the risk sacrifices computational efficiency.

The solution found in Scenario 1 obtained when running the Cycle Charge strategy with CNSE = 2.5 (the highlighted point in Figure 41) is one such example:

- 1) The optimal solution found by the Cycle Charge strategy returns a solution that is not optimal [11.48 kW= solar, 0 kWh = storage, 8 kW = ICE].
- 2) When the dispatch strategy was run with [11.48 kW = solar, 0 kWh = storage, 10 kW =ICE], the annuity obtained was less than the annuity associated with the false-optimal.
- 3) This leads to the conclusion that the false-optimal is evidently a local minimum.

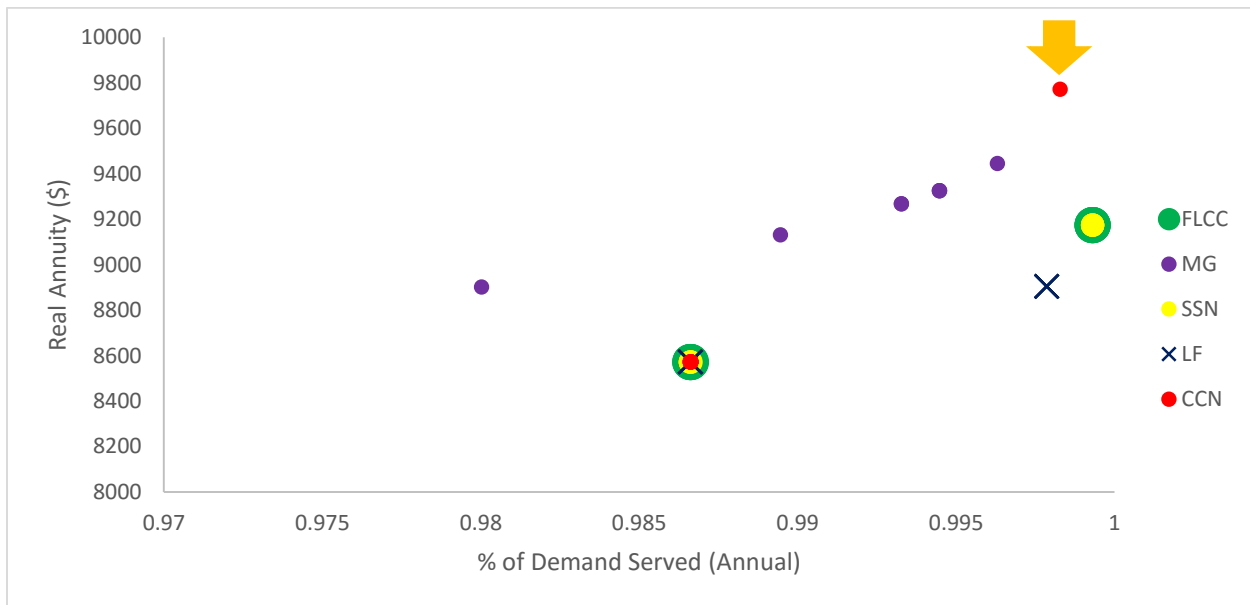

Figure 41. An example of a local minimum (highlighted by the orange arrow)

For practical reasons, the problem of “falling into” a local minimum cannot be entirely avoided. It would simply be too time intensive to test all possible combinations. The goal of the search is to apply a reasonable logic to minimize computational efficiency and the chances of landing in local minima. A more thorough search may be more inefficient to conduct, but may also increase the probability that the solution found is the global minimum. Indeed, we find that the search is frequently subject to “flatness” - solutions that are very different from each other can have very similar annuities. This arises from the tradeoffs in curtailing demand vs. investment and operational costs of meeting demand. The issue of local minima may also be exacerbated by the discreteness of the generation assets. Non-linear trends in the input data, whether purposeful or not, could very well create local minima conditions.

Chapter 7: Conclusions

In the proceeding chapters, I have described the development and applications of a computational microgrid tool designed specifically for the developing context. The work described in this thesis contributes to rural electrification planning in two ways. Firstly, improvements made to the simulation of microgrid operations will be integrated into the parent tool, REM. Secondly (and the focus of this thesis), LREM has been developed as a comprehensive package capable of performing four essential tasks. It:

1. Chooses the optimal generation mix.
2. Simulates operational performance.
3. Produces an optimal network design.
4. Outputs relevant performance indicators and financial metrics.

In Chapter 5, I demonstrated how LREM can provide benchmarking and analytics useful to the design process of a real village. Chapter 6 performed an in-depth comparative analysis of operational strategies and generation design. In Part A of chapter 6, I demonstrated how the performance of each operational strategy varies by examining the implications of variation in solar and storage resources on the performance of operational strategies. Part B sought to understand how the choice of operational strategy affects the optimal generation design output. The major findings from both parts of the sensitivity analysis are summarized below:

1. The choice of operational design can affect the performance of the microgrid, and the operational strategy is an important factor in generation design.
2. The relative cost of diesel to battery storage has significant effects on the optimal generation design.
3. Operational strategies perform best under specific conditions, and this is due to the logic defining their behavior.

Together, these results illustrate the complexities of generation design, and demonstrate the difficulty in sizing assets optimally. Given this, the computational rigor of LREM could absolutely add value assist by providing design guidance.

I have shown that LREM provides the analytics needed to improve financial and technical viabilities of rural microgrids. But what about scale? We seek to facilitate access to LREM, not only by providing it for free, but by offering it as an open-sourced tool. Interested users will be able to customize the tool to best match the operations of their systems. More so than that, by crowdsourcing LREM, the team hopes to promote its development, implementation, and ultimately, accelerate energy access. Given its capabilities and the strength of its ambitions, I ultimately conclude that LREM does indeed add value as an electrification access support tool.

References

1. International energy Agency (IEA) and the World Bank. (2015). "Sustainable Energy for All 2015 – Progress Toward Sustainable Energy", World Bank, Washington, DC. DOI:10.1596/978-4648-0690-2.
2. Schnitzer, D., Lounsbury, D. S., Carvallo, J. P., Deshmukh, R., Apt, J., Kammen, D. M. 2014. Microgrids for Rural Electrification: A Critical Review of best Practices Based on Seven Case Studies. United Nations Foundation. Available from: https://wpweb2.tepper.cmu.edu/ceic/pdfs_other/Micro-grids_for_Rural_Electrification-A_critical_review_of_best_practices_based_on_seven_case_studies.pdf
3. Smith N, Taylor P and T Matthews. 2003. Improving the cost-effectiveness of small hydro through intelligent load management. SHP Development and Programme Worldwide Newsletter. Available from: [http://www.hrcshp.org/cn/chshpdb/db/UK/Improving%20the%20costeffectiveness%20of%20small%20hydro%20through%20intelligent%20load%20management\(2003sum\).pdf](http://www.hrcshp.org/cn/chshpdb/db/UK/Improving%20the%20costeffectiveness%20of%20small%20hydro%20through%20intelligent%20load%20management(2003sum).pdf)
4. Smith, N., Taylor, P., Matthews, T. 2003. Switched-On Energy Saving. International Water Power and Dam Construction.
5. Harper, M.J. 2013. Implementing Gridshare Technology in rural Bhutan: Analyzing Effects on Electrical Brownouts and Assessing Community Acceptance (Master's thesis). Retrieved from: http://humboldt-space.calstate.edu/bitstream/handle/2148/1653/harper_margaret_j_Fa2013.pdf?sequence=1
6. Circutor. 2012. Renewable Energies. Available from: http://circutor.com/energy/renewable---energies_a_1127.aspx
7. Harper, M. 2013. Review of Strategies and Technologies for Demand-Side Management on Isolated Mini-Grids. Schantz Energy Research Center. Retrieved from: http://www.cleanenergyministerial.org/Portals/2/pdfs/Review_of_Strategies_and_Technologies_for_DS_M_on_MiniGrids.pdf
8. Gram Power. Retrieved From: <http://www.grampower.com/about-us/>
9. Lambert, T., Gilman, P., Lilienthal, P. 2006. Micropower System Modeling with HOMER.
10. Berkeley Lab. Distributed Energy Resources Customer Adoption Model (DER-CAM). <https://building-microgrid.lbl.gov/projects/der-cam>
11. Green, H.J., Manwell, J. Hybrid2: A Versatile Model of the Performance of Hybrid Power Systems. The National Renewable Energy Laboratory. <http://www.nrel.gov/docs/legosti/old/7807.pdf>
12. Hybrid2. The University of Massachusetts Wind Energy Center. Available from: <http://www.umass.edu/windenergy/research/topics/tools/software/hybrid2>
13. Baring-Gould, E.I., Green, H.J., vanDijk, V.A.P., Manwell, J.F. 1996. Hybrid2 – The Hybrid Power System Simulation Model. National Renewable Energy Laboratory. NREL/TP-440-21506. Available from: <http://www.nrel.gov/docs/legosti/old/21506.pdf>
14. The Network Planner [Computer Software]. Available from: <http://networkplanner.modilabs.org/scenarios/1979.html>
15. Kemausuor, F., Adkins, E., Adu-Poku, I., Brew-Hammond, A., Modi., V. 2014. Electrification Planning Using Network Planner Tool: The Case of Ghana. Energy for sustainable Development. 19 (2014) 92-101.
16. GridLAB-D. 2012. A Unique Tool to Design the Smart Grid. The Pacific Northwest National Laboratory. http://www.gridlabd.org/brochures/20121130_gridlabd_brochure.pdf
17. GridLAB-D. Pacific Northwest National Laboratory. PNNL-SA-54904. Available from: http://eioc.pnnl.gov/brochures/gridlab_d.pdf
18. Ellman, D. 2015. The Reference Electrification Model: A Computer Model for Planning Rural Electricity Access (Master's Thesis). Submitted to Humbolt State University. Available from: <https://dspace.mit.edu/bitstream/handle/1721.1/98551/920674644-MIT.pdf?sequence=1>

19. Cadex Electronics Inc. Battery University - BU-201: How does the Lead Acid. Available from: http://batteryuniversity.com/learn/article/lead_based_batteries
20. Cadex Electronics Inc. Battery University - What's the Best Battery? Available from: http://batteryuniversity.com/learn/article/whats_the_best_battery.
21. HOMER [Computer Software]. Retrieved from: www.homerenergy.com
22. Manwell, J.F., McGowan, F. G. 1993. Lead Acid Battery Storage Model for Hybrid Energy Systems. *Solar Energy*. Vol. 50. No. 5. Pp. 399-405.
23. Silver, E., Vidal, V., De-Werra, D. 1980. A Tutorial on Heuristic Methods. *European Journal of Operational Research*. 5 (1980) 153-162.
24. Barley C. D., Winn, C., B. 1996. Optimal Dispatch Strategy in remote Hybrid Power Systems. Pergamon. PIL:S0038-092X(96)00087-4.
25. Quetchenbach, T.G., Harper, M. J., Robinson IV, J., Herwin, K. K., Chase, N. A., Dorji, C., Jacobson, A. E. 2012. The GridShare solution: A Smart Grid Approach to Improve Service Provision on a Renewable Energy Mini-Grid in Bhutan. *Environmental Research Letters*. 8 014018.
26. Palma-Behnke, R., Benavides, C., Lanas, F., Lanas, F., Serverino, B., Reyes, L., Llanos, J., Saez, D. 2013. A Microgrid Energy Management System Based on the Rolling Horizon Strategy. *IEEE Transactions on Smart Grid*. Vol. 4, No. 2.
27. Rolland, S., Glania, G. 2011. Hybrid Mini-Grids for Rural Electrification: Lessons Learned. USAID, Alliance for Rural Electrification.
28. Santos-Pérez, I. F. 2015. Metodología de Ayuda a la Decisión Para La Electrificación Rural Apropriadada en Países en Vías de Desarrollo (PhD Dissertation). Submitted to Comillas University, Madrid.
29. Briganti, M., Vallve, X., Alves, L., Pujol, D., Cabral, J., Lopes, C. 2012. Implementation of a PV Rural Microgrid in the Island of Santo Antao (Cape Verde) with an Individual Energy Allowance Scheme for Demand Control. Presented at the 27th European Photovoltaic Solar Energy Conference and Exhibition. Frankfurt, Germany.
30. Harper, M. 2013. Review of Strategies and Technologies for Demand-Side Management on Isolated Mini Grids. Lawrence Berkeley National Laboratory.
31. Campanella, A. 2013. An Analysis of the Viability and Competitiveness of DC Microgrids in Northern India. (Master's Thesis). Submitted to the Massachusetts Institute of Technology. Available from: <https://dspace.mit.edu/handle/1721.1/100357>.

Appendix

This material compliments the discussion of the operational strategies in Chapter 4.

Description of Variables

A list of the variables and parameters are presented in the tables of this section.

Table A 1. The variables and parameters used in the flow charts describing the Simplest DC, Cycle Charge, Load Following, and Forward Looking Cycle Charge strategies

Hourly Variables	
$l(i)$	The aggregate load
$Ppv(i)$	The total solar power
$Pbatt_out_max(i)$	The maximum power output from the battery bank, as determined by the KiBaM
$Pbatt_in_max(i)$	The maximum power input from the battery bank, as determined by the KiBaM
$Pbatt_bal(i)$	An intermediate variable in determining the dispatch of the battery
$Pgen_bal(i)$	An intermediate variable in determining the dispatch of the generator
$Unmet_Load(i)$	The curtailed load
$Pbatt(i)$	An intermediate variable defining the battery dispatch, and is “sorted” in Step 2 into either power entering or exiting the battery based on the sign of its value
$Pdiss_DC(i)$	DC power that is spilled (power that cannot be taken in by the battery)
$Pdiss_AC(i)$	Spilled AC power from the ICE
$P_gen1(i)$	The dispatched power output from the ICE
$Pin_batt(i)$	The final battery power input
$Pout_batt(i)$	The final battery power output
$next_PVSpill(i)$	The estimated incidences in which solar power is spilled in the next period of sunlight
Parameters	
$pMin$	The minimum power output of the generator
$pMax$	The maximum power output of the generator
eta_inv	The inverter efficiency
eta_rect	The rectifier efficiency
SOC_set	The SOC threshold value, used in determining when the generator should be run at maximum power
$PVSpill_set$	The threshold incidences of spilled power in each period of sunlight, used in determining when the generator should be run at maximum power

Table A 2. The variables and parameters used in the flow charts describing the Advanced Battery Valuation strategy

Hourly Variables	
$Stack_1$	Contains a list of the resources ordered by cost of the resource when used to meet demand (from least to most expensive)
$Stack_2$	Contains a list of the resources ordered by the cost of the resource when used to charge the battery (from least to most expensive)
$valBattery(i)$	The value of the battery
$maxed.solar(i)$	A binary variable signaling whether solar power has been completely used up
$maxed.gen(i)$	A binary variable signaling whether the generator is functioning at maximum power
$maxed.ptyLo(i)$	A binary variable signaling whether all low priority demand has been curtailed
$maxed.battOut(i)$	A binary variable signaling whether the battery is outputting at max power
$dispatch.solar(i)$	The amount of PV power used to meet the load
$dispatch.gen(i)$	The power output of the generator
$dispatch.crtllo(i)$	The amount of low priority demand curtailed
$dispatch.crtlhi(i)$	The amount of high priority demand curtailed
$dispatch.battout(i)$	The power output of the battery, as determined by the KiBaM
$Dispatch.battin(i)$	The power input of the battery, as determined by the KiBaM
$battEoutMax(i)$	The maximum output of the battery as defined by

Balance(i)	An intermediate variable indicating the balance of generation and the demand with losses
solarE(i)	The total amount of available solar power
demandSample.loPty(i)	The total low priority demand
demandSample.hiPty(i)	The total high priority demand
CostOption1	This is the cost associated with the first dispatch option, in the case when the generator outputs at less than its minimum power output.
CostOption2	This is the cost associated with the second dispatch option, in the case when the generator outputs at less than its minimum power output.
Parameters	
Pmin	The minimum power output of the diesel generator
genEMax	The maximum power output of the diesel generator

Flow Charts

The logic of the operational strategies is described in an algorithmic manner in the following figures. Restrictions on page size have forced many of the diagrams to be presented in multiple blocks. Please also note that Step 2 of the Simplest DC, Load Following, Cycle Charge, and Forward Looking Cycle Charge strategies are the same and are presented only once.

Simplest DC Strategy

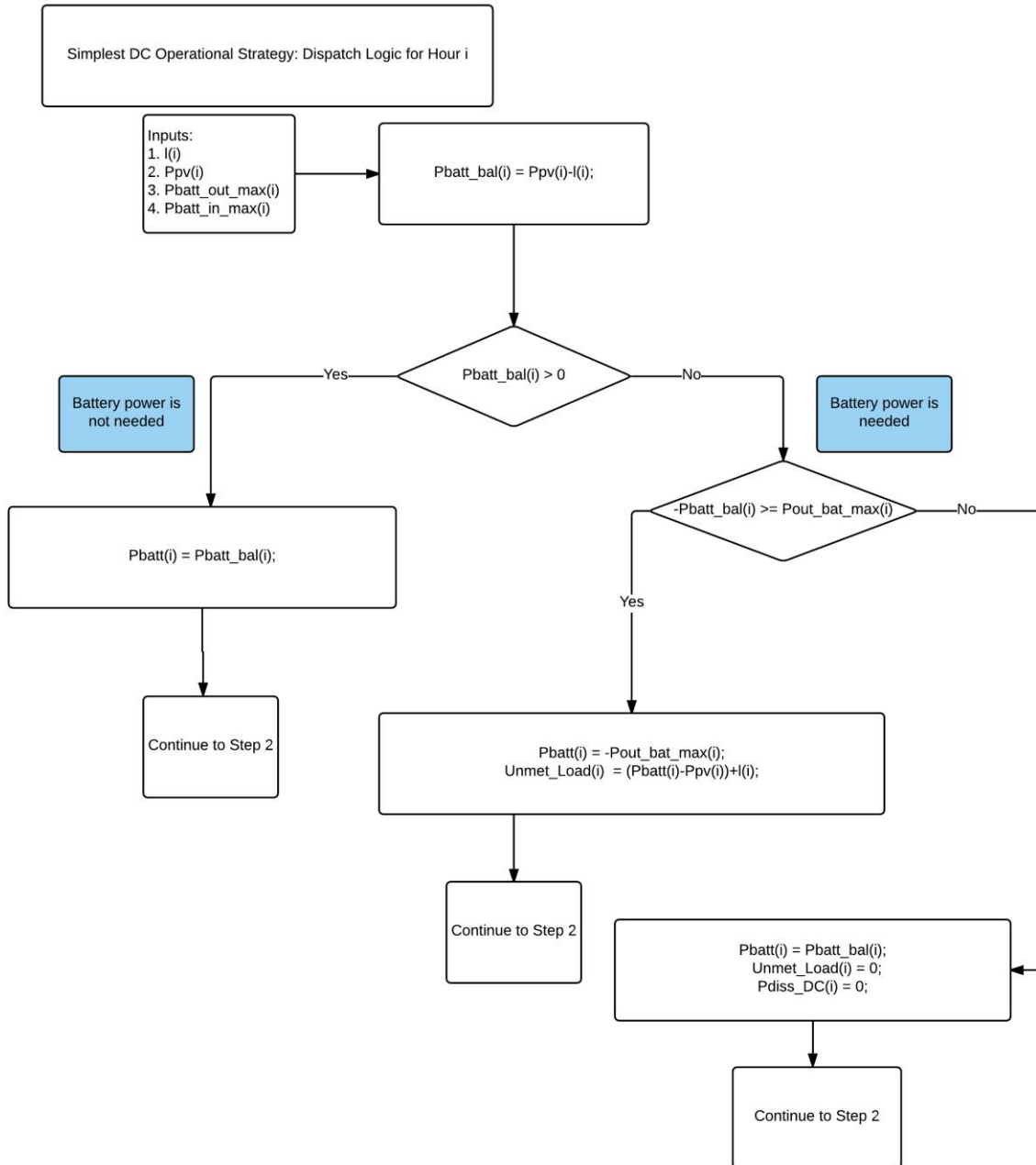

Step 2 of the Simplest Dispatch, Load Following, Cycle Charge, Forward Looking Cycle Charge Strategies

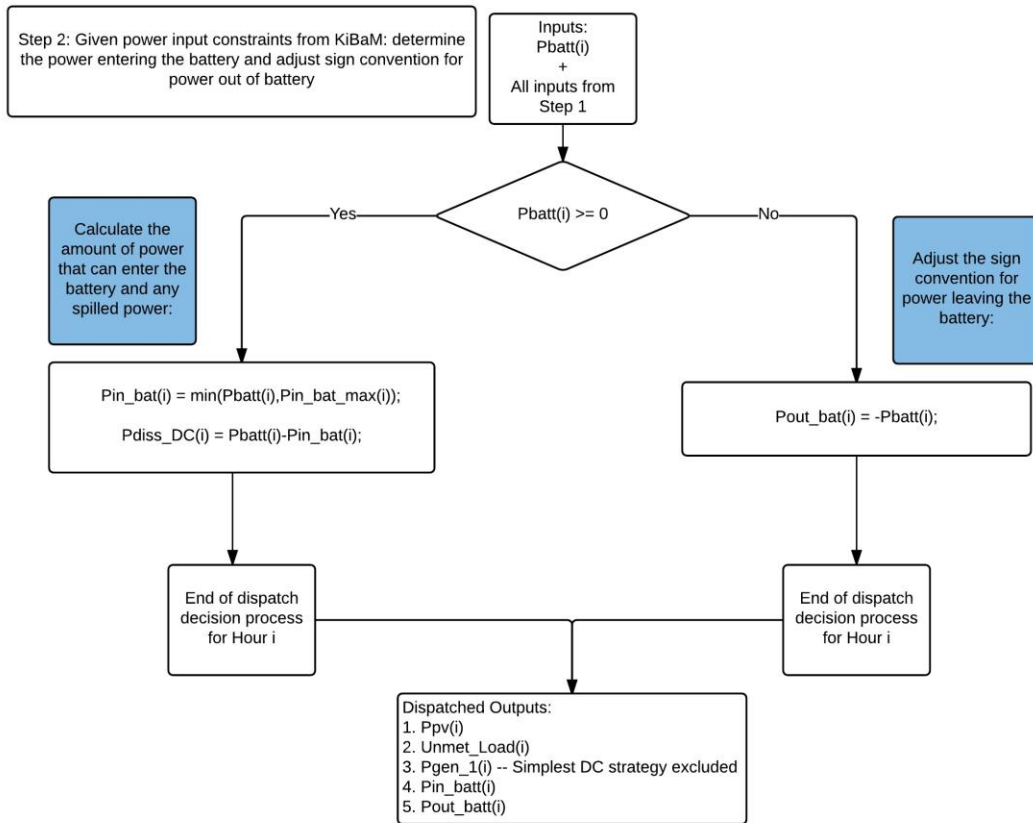

The Load Following Strategy

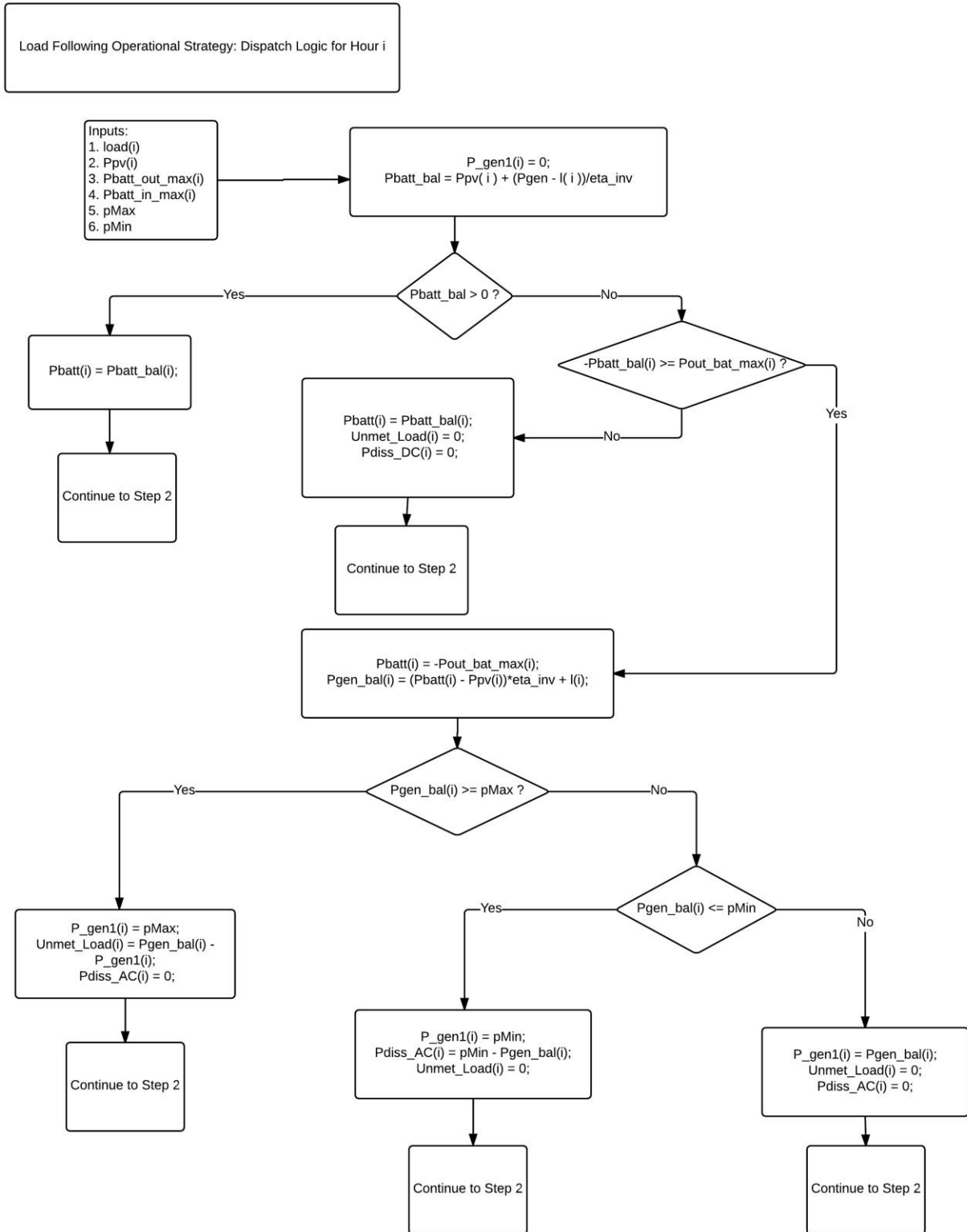

Cycle Charge Strategy

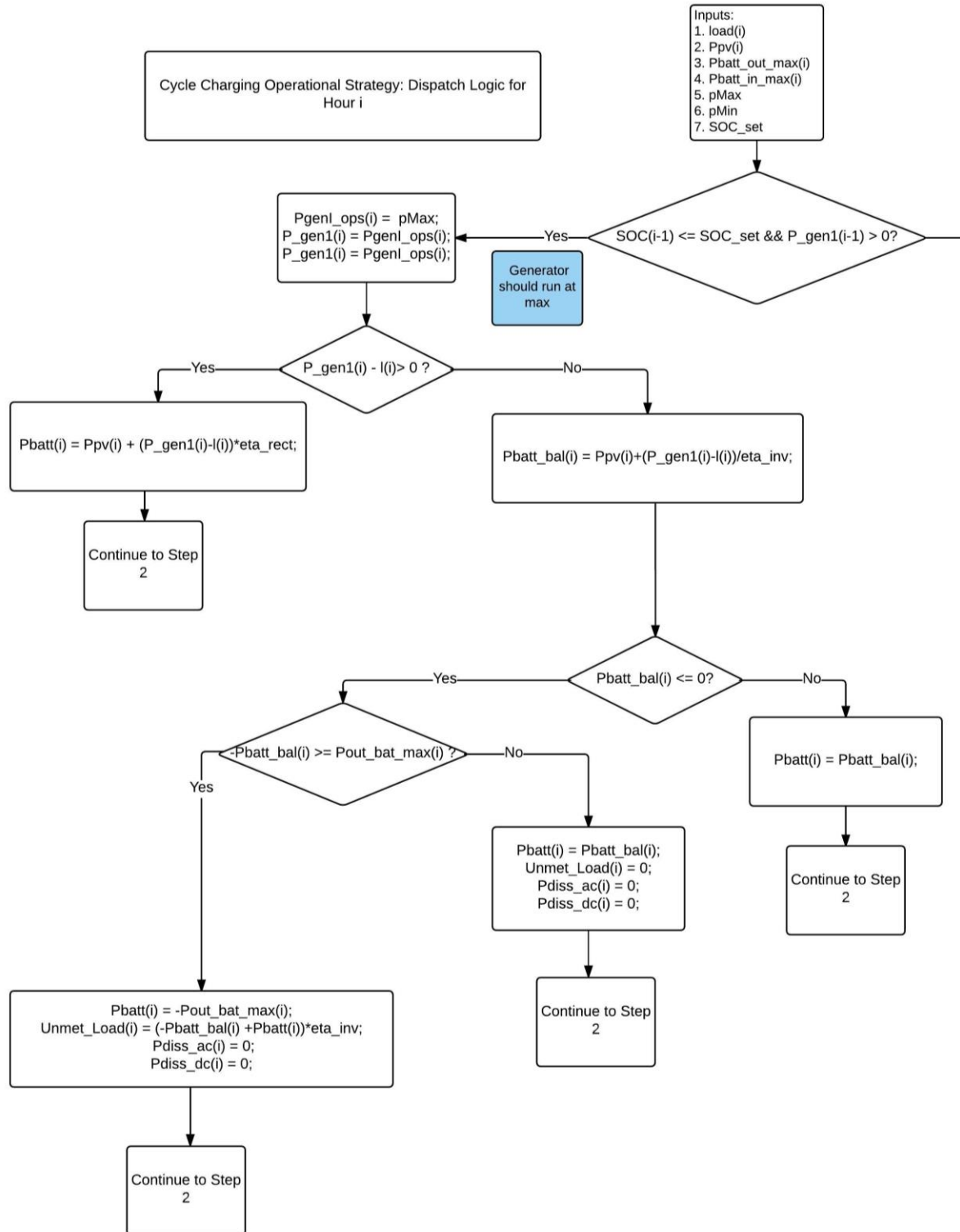

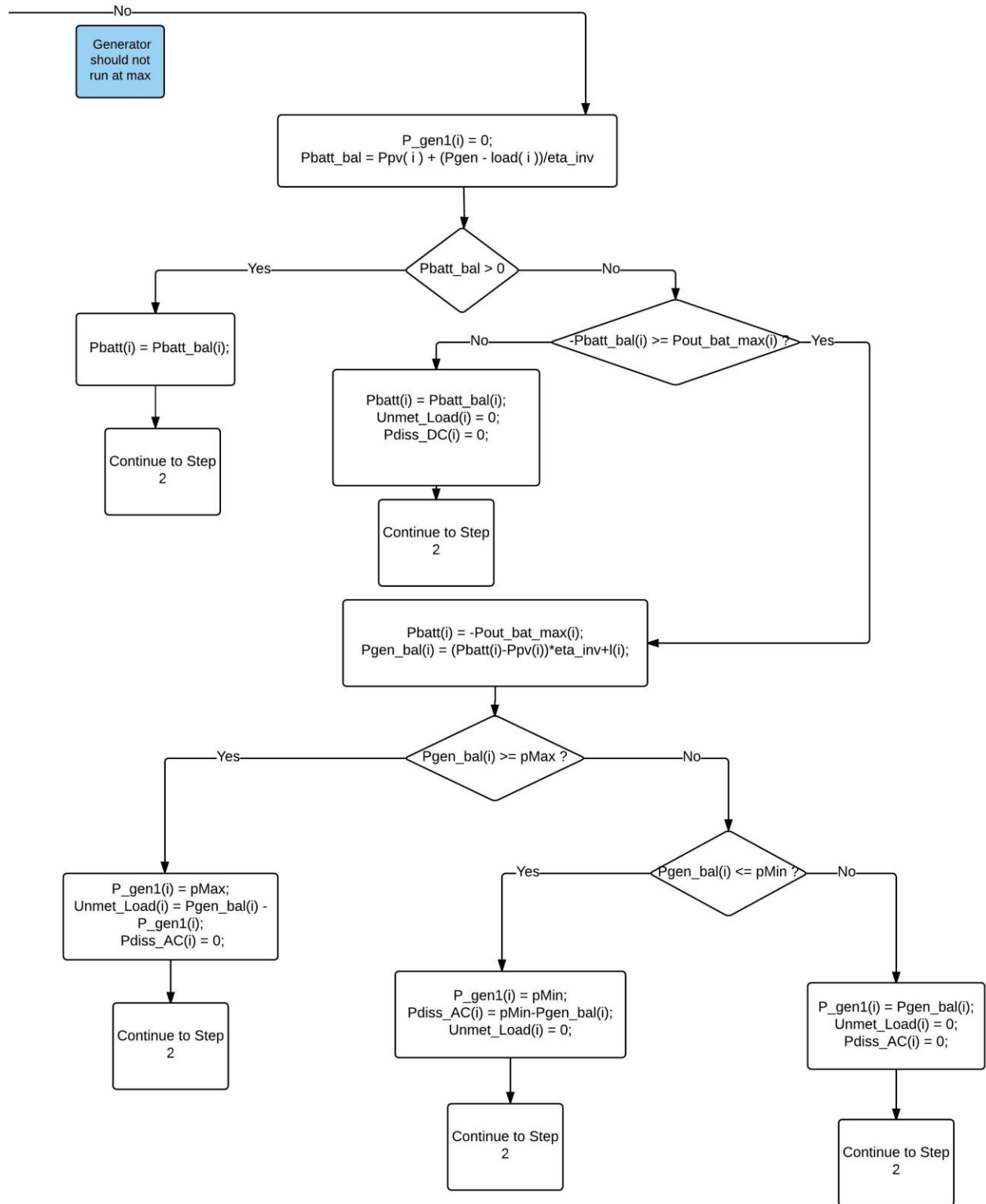

Forward Looking Cycle Charge Strategy

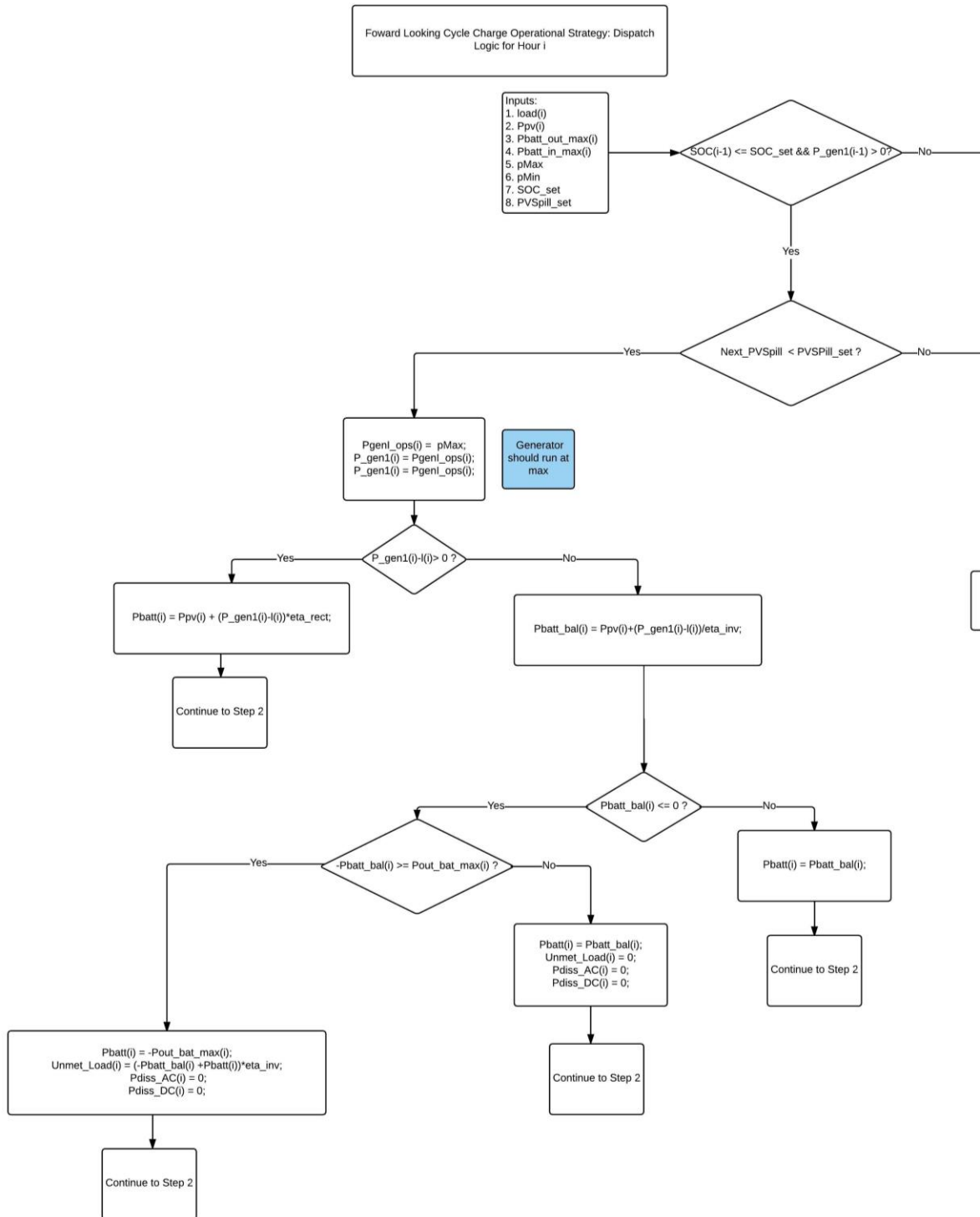

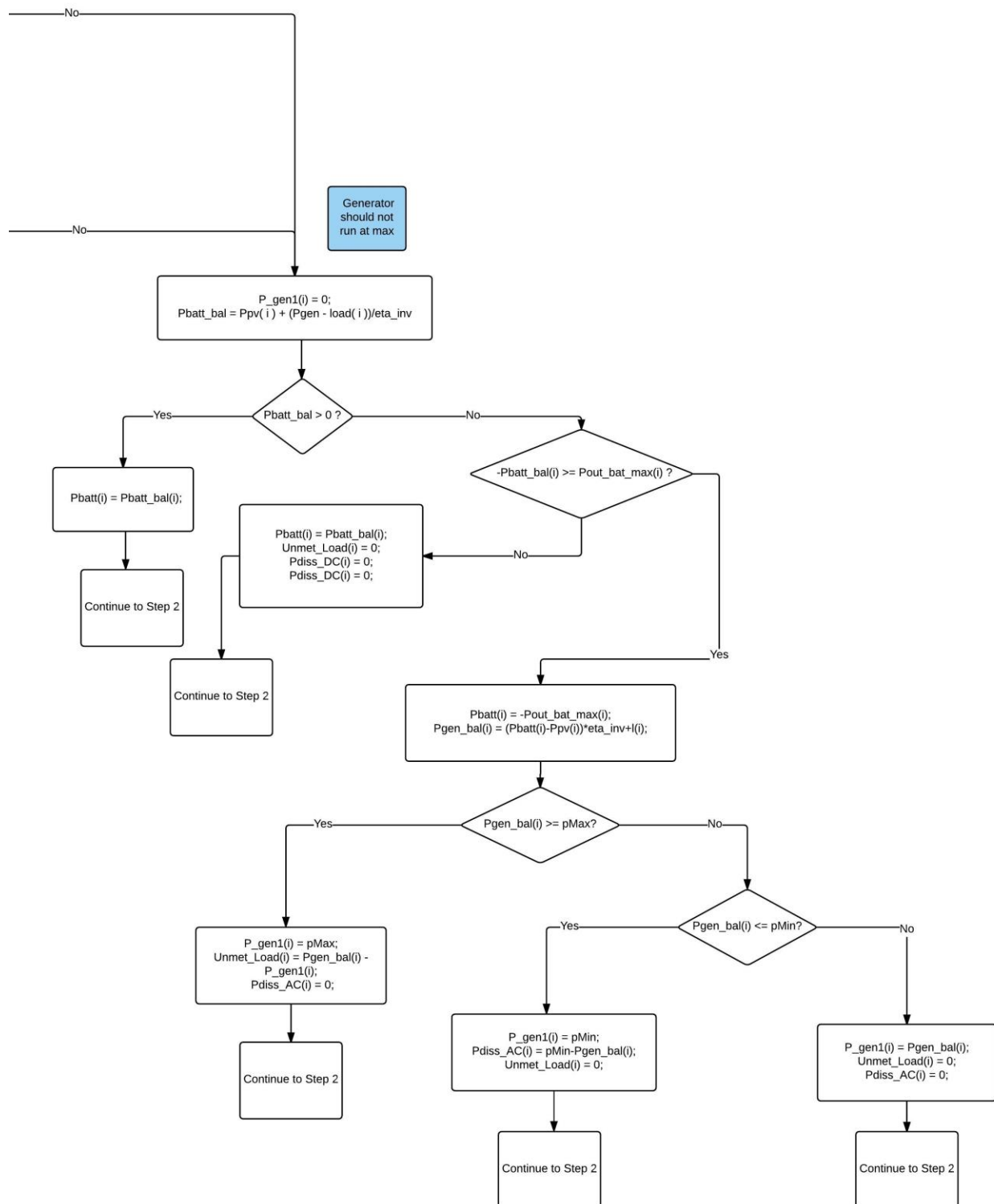

Advanced Battery Valuation Strategy

Advanced Battery Valuation Operational Strategy:
Dispatch Logic for Hour i

